

GROOMING MOWERS

GM3054

GM3060

GM3072

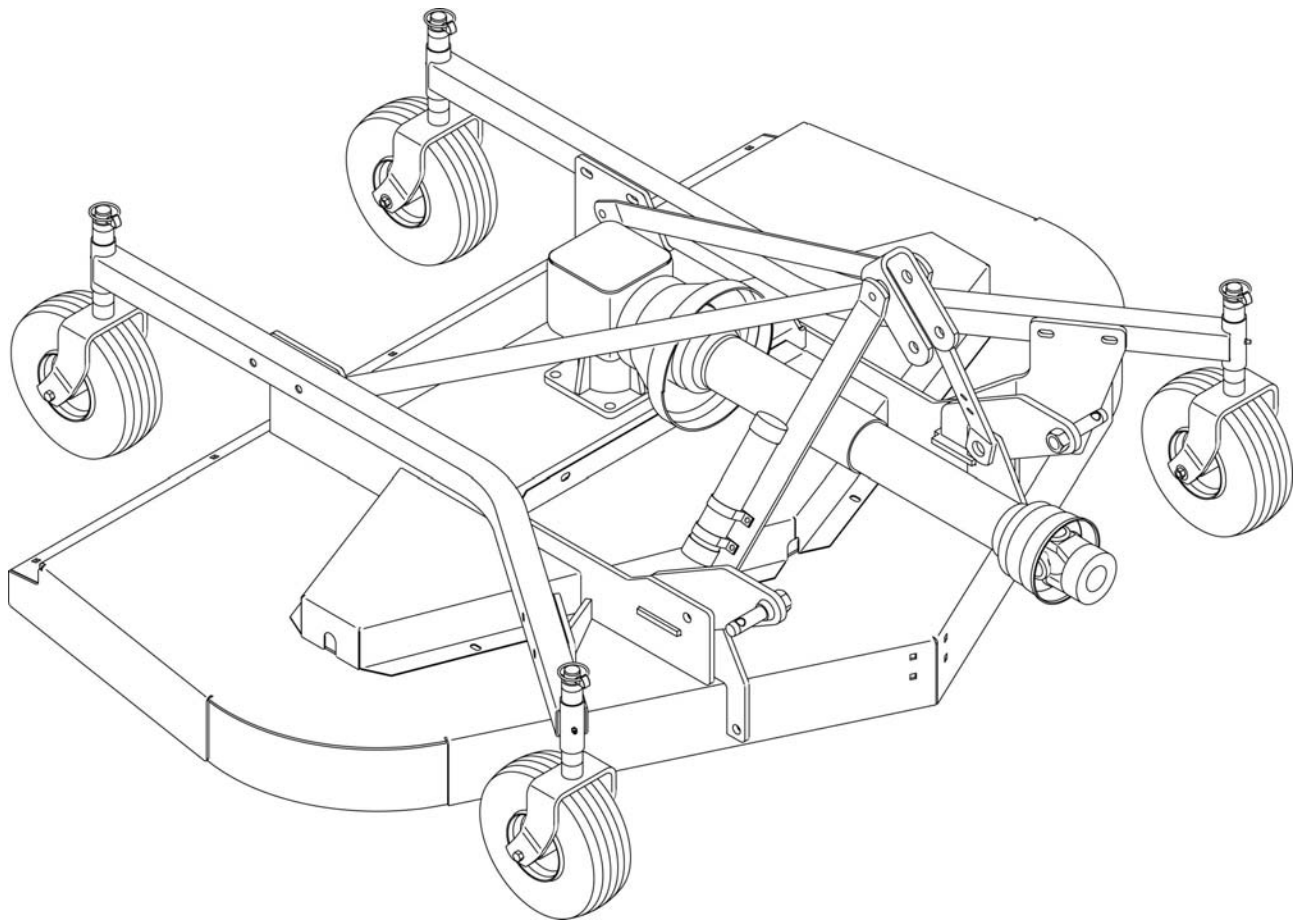

FRONTIERTM

TO THE DEALER:

Assembly and proper installation of this product is the responsibility of the Frontier dealer. Read manual instructions and safety rules. Make sure all items on the Dealer's Pre-Delivery and Delivery Check Lists in the Operator's Manual are completed before releasing equipment to the owner.

TO THE OWNER:

Read this manual before operating your Frontier equipment. The information presented will prepare you to do a better and safer job. Keep this manual handy for ready reference. Require all operators to read this manual carefully and become acquainted with all the adjustment and operating procedures before attempting to operate. Replacement manuals can be obtained from your selling dealer.

The equipment you have purchased has been carefully engineered and manufactured to provide dependable and satisfactory use. Like all mechanical products, it will require cleaning and upkeep. Lubricate the unit as specified. Observe all safety information in this manual and safety decals on the equipment.

For service, your authorized Frontier dealer has trained mechanics, genuine Frontier service parts, and the necessary tools and equipment to handle all your needs.

Use only genuine Frontier service parts. Substitute parts will void the warranty and may not meet standards required for safe and satisfactory operation. Record the model number and serial number of your equipment in the spaces provided:

Model: _____ **Date of Purchase:** _____

Serial Number: (see Safety Decal section for location) _____

Provide this information to your dealer to obtain correct repair parts.

Throughout this manual, the term **NOTICE** is used to indicate that failure to observe can cause damage to equipment. The terms **CAUTION**, **WARNING** and **DANGER** are used in conjunction with the Safety-Alert Symbol, (a triangle with an exclamation mark), to indicate the degree of hazard for items of personal safety.



This is the safety alert symbol. It is used to alert you to potential physical injury hazards. Obey all safety messages that follow this symbol to avoid possible injury or death.



Indicates a hazardous situation that, if not avoided, will result in death or serious injury.



Indicates a hazardous situation that, if not avoided, could result in death or serious injury.



Indicates a hazardous situation that, if not avoided, could result in minor or moderate injury.

IMPORTANT
or **NOTICE**

Is used to address practices not related to physical injury.

NOTE

Indicates helpful information.

TABLE OF CONTENTS

INTRODUCTION	2
SPECIFICATIONS	4
GENERAL INFORMATION	4
SAFETY RULES	5
SAFETY DECALS	8
OPERATION	10
OWNER SERVICE	14
TROUBLESHOOTING	18
DEALER SERVICE	20
ASSEMBLY	27
DEALER CHECK LISTS	31
PARTS LISTS	33
BOLT TORQUE CHART	42
BOLT SIZE CHART & ABBREVIATIONS	43
INDEX	44

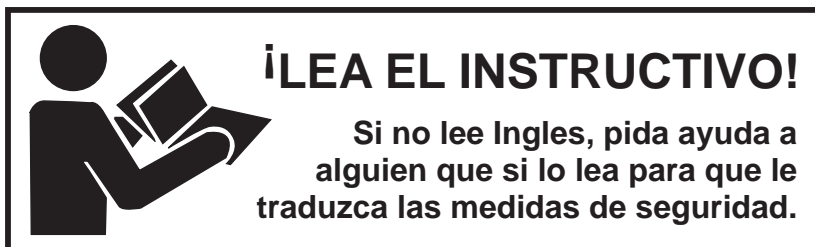

This Operator's Manual should be regarded as part of the machine. Suppliers of both new and second-hand machines must make sure that this manual is provided with the machine.

SPECIFICATIONS

<u>MODEL</u>	<u>GM3054</u>	<u>GM3060</u>	<u>GM3072</u>
3-Point Hitch	Limited Cat. 1	Cat. 1	Cat. 1
Cutting Width	54"	60"	72"
Cutting Height Range	1" - 4-1/2"	1" - 4-1/2"	1" - 4-1/2"
Operating Weight with Chain Shielding	417 lbs.	521 lbs.	624 lbs.
Blade Speed (feet per minute)	16,200	18,000	18,100
Blade Spindles	3	3	3
Number of Blades	3	3	3
Universal Drive Series	ASAE Cat. 3	ASAE Cat. 3	ASAE Cat. 3
Implement Code for Tractor Ballast	25.4	31.7	38.0
Caster Wheels	3.5 x 4 x 10	3.5 x 4 x 10	3.5 x 4 x 10
Tractor PTO Speed RPM	540	540	540
Recommended Maximum Tractor Horsepower	15-25	25-35	25-35
Mower Frame Thickness	10 GA	8 GA	8 GA

GENERAL INFORMATION

WARNING

■ Some illustrations in this manual show the equipment with safety shields removed to provide a better view. This equipment should never be operated with any necessary safety shielding removed.

The purpose of this manual is to assist you in operating and maintaining your mower. Read it carefully. It furnishes information and instructions that will help you achieve years of dependable performance. These instructions have been compiled from extensive field

experience and engineering data. Some information may be general in nature, due to unknown and varying operating conditions. However, through experience and these instructions, you should be able to develop procedures suitable to your particular situation.

The illustrations and data used in this manual were current at the time of printing. However, due to possible inline production changes, your machine may vary slightly in detail. We reserve the right to redesign and change the machines as may be necessary without notification.

Throughout this manual, references are made to right and left directions. These are determined by standing behind the tractor facing the direction of forward travel.

4 Introduction

5WPMAN0705 (Rev. 2/16/2009)

SAFETY RULES



ATTENTION! BECOME ALERT! YOUR SAFETY IS INVOLVED!



Safety is a primary concern in the design and manufacture of our products. Unfortunately, our efforts to provide safe equipment can be wiped out by an operator's single careless act.

In addition to the design and configuration of equipment, hazard control and accident prevention are dependent upon the awareness, concern, judgement, and proper training of personnel involved in the operation, transport, maintenance and storage of equipment.

It has been said "The best safety device is an informed, careful operator." We ask you to be that kind of operator.

TRAINING

- **Safety instructions are important! Read all attachment and power unit manuals; follow all safety rules and safety decal information. (Replacement manuals and safety decals are available from your dealer.) Failure to follow instructions or safety rules can result in serious injury or death.**
- **Know your controls and how to stop engine and attachment quickly in an emergency.**
- **If you do not understand any part of this manual and need assistance, see your dealer.**
- **Operators must be instructed in and be capable of the safe operation of the equipment, its attachments, and all controls. Do not allow anyone to operate this equipment without proper instructions.**
- **Never allow children or untrained persons to operate equipment.**

PREPARATION

- **Check that all hardware is properly installed. Always tighten to torque chart specifications unless instructed otherwise in this manual.**
- **Always wear relatively tight and belted clothing to avoid entanglement in moving parts. Wear sturdy, rough-soled work shoes and protective equipment for eyes, hair, hands, hearing, and head; and respirator or filter mask where appropriate.**
- **Make sure attachment is properly secured, adjusted, and in good operating condition.**
- **Make sure spring-activated locking pin or collar slides freely and is seated firmly in tractor PTO spline groove.**

- **Connect PTO driveline directly to power unit PTO shaft. Never use adapter sleeves or adapter shafts. Adapters can cause driveline failures due to incorrect spline or incorrect operating length and can result in personal injury or death.**

- **Make sure driveline shield tether chains are attached to the tractor and equipment as shown in this manual. Replace if damaged or broken. Check that driveline guards rotate freely on driveline before putting equipment into service.**

- **Before starting power unit, check all equipment driveline guards for damage. Replace any damaged guards. Make sure all guards rotate freely on all drivelines. If guards do not rotate freely on drivelines, repair and replace bearings before putting equipment into service.**

- **Power unit must be equipped with ROPS or ROPS cab and seat belt. Keep seat belt securely fastened. Falling off power unit can result in death from being run over or crushed. Keep foldable ROPS systems in "locked up" position at all times.**

- **Remove accumulated debris from this equipment, power unit, and engine to avoid fire hazard.**

- **Make sure all safety decals are installed. Replace if damaged. (See Safety Decals section for location.)**

- **Make sure shields and guards are properly installed and in good condition. Replace if damaged.**

- **A minimum 20% of tractor and equipment weight must be on the tractor front wheels when attachments are in transport position. Without this weight, tractor could tip over, causing personal injury or death. The weight may be attained with front wheel weights, ballast in tires or front tractor weights. Weigh the tractor and equipment. Do not estimate.**

OPERATION

- **Inspect and clear area of stones, branches, or other hard objects that might be thrown, causing injury or damage.**

- **Never direct discharge toward people, animals, or property.**

- **Keep bystanders away from equipment.**

(Safety Rules continued on next page)



SAFETY RULES

ATTENTION! BECOME ALERT! YOUR SAFETY IS INVOLVED!



(Safety Rules continued from previous page)

■ Full chain shielding must be installed when operating in populated areas or other areas where thrown objects could injure people or damage property.

- If this machine is not equipped with full chain shielding, operation must be stopped when anyone comes within 300 feet (92 m).
- This shielding is designed to reduce the risk of thrown objects. The mower deck and protective devices cannot prevent all objects from escaping the blade enclosure in every mowing condition. It is possible for objects to ricochet and escape, traveling as much as 300 feet (92 m).

■ Do not operate or transport equipment while under the influence of alcohol or drugs.

■ Operate only in daylight or good artificial light.

■ Keep hands, feet, hair, and clothing away from equipment while engine is running. Stay clear of all moving parts.

■ Always comply with all state and local lighting and marking requirements.

■ Never allow riders on power unit or attachment.

■ Always sit in power unit seat when operating controls or starting engine. Securely fasten seat belt, place transmission in neutral, engage brake, and ensure all other controls are disengaged before starting power unit engine.

■ Operate tractor PTO at 540 RPM. Do not exceed.

■ Look down and to the rear and make sure area is clear before operating in reverse.

■ Do not operate or transport on steep slopes.

■ Do not stop, start, or change directions suddenly on slopes.

■ Use extreme care and reduce ground speed on slopes and rough terrain.

■ Watch for hidden hazards on the terrain during operation.

■ Stop power unit and implement immediately upon striking an obstruction. Dismount power unit, using proper procedure. Inspect and repair any damage before resuming operation.

TRANSPORTATION

■ Use additional caution and reduce speed when under adverse surface conditions, turning, or on inclines.

■ Do not operate PTO during transport.

■ A minimum 20% of tractor and equipment weight must be on the tractor front wheels when attachments are in transport position. Without this weight, tractor could tip over, causing personal injury or death. The weight may be attained with front wheel weights, ballast in tires or front tractor weights. Weigh the tractor and equipment. Do not estimate.

■ Do not operate or transport on steep slopes.

■ Do not operate or transport equipment while under the influence of alcohol or drugs.

■ Always comply with all state and local lighting and marking requirements.

■ Never allow riders on power unit or attachment.

MAINTENANCE

■ Before working underneath, carefully read Operator's Manual instructions, disconnect driveline, raise mower, securely block up all corners with jackstands, and check stability. Secure blocking prevents equipment from dropping due to hydraulic leak down, hydraulic system failures, or mechanical component failures.

■ Do not modify or alter or permit anyone else to modify or alter the equipment or any of its components in any way.

■ Always wear relatively tight and belted clothing to avoid entanglement in moving parts. Wear sturdy, rough-soled work shoes and protective equipment for eyes, hair, hands, hearing, and head; and respirator or filter mask where appropriate.

■ Make sure attachment is properly secured, adjusted, and in good operating condition.

■ Keep all persons away from operator control area while performing adjustments, service, or maintenance.

■ Make certain all movement of equipment components has stopped before approaching for service.

(Safety Rules continued on next page)

SAFETY RULES



ATTENTION! BECOME ALERT! YOUR SAFETY IS INVOLVED!



(Safety Rules continued from previous page)

- **Never go underneath equipment (lowered to the ground or raised) unless it is properly blocked and secured. Never place any part of the body underneath equipment or between moveable parts even when the engine has been turned off. Hydraulic system leak down, hydraulic system failures, mechanical failures, or movement of control levers can cause equipment to drop or rotate unexpectedly and cause severe injury or death. Follow Operator's Manual instructions for working underneath and blocking requirements or have work done by a qualified dealer.**
- **Frequently check blades. They should be sharp, free of nicks and cracks, and securely fastened.**
- **Do not handle blades with bare hands. Careless or improper handling may result in serious injury.**
- **Your dealer can supply genuine replacement blades. Substitute blades may not meet original equipment specifications and may be dangerous.**
- **Tighten all bolts, nuts, and screws to torque chart specifications. Check that all cotter pins are**

installed securely to ensure equipment is in a safe condition before putting unit into service.

- **Make sure all safety decals are installed. Replace if damaged. (See Safety Decals section for location.)**
- **Make sure shields and guards are properly installed and in good condition. Replace if damaged.**
- **Wear gloves when installing belt. Be careful to prevent fingers from being caught between belt and pulley.**
- **Use care when installing or removing belt from spring-loaded idler. Springs store energy when extended and, if released suddenly, can cause personal injury.**

STORAGE

- **Follow manual instructions for storage.**
- **Keep children and bystanders away from storage area.**



SAFETY & INSTRUCTIONAL DECALS



ATTENTION! BECOME ALERT! YOUR SAFETY IS INVOLVED!
Replace Immediately If Damaged!

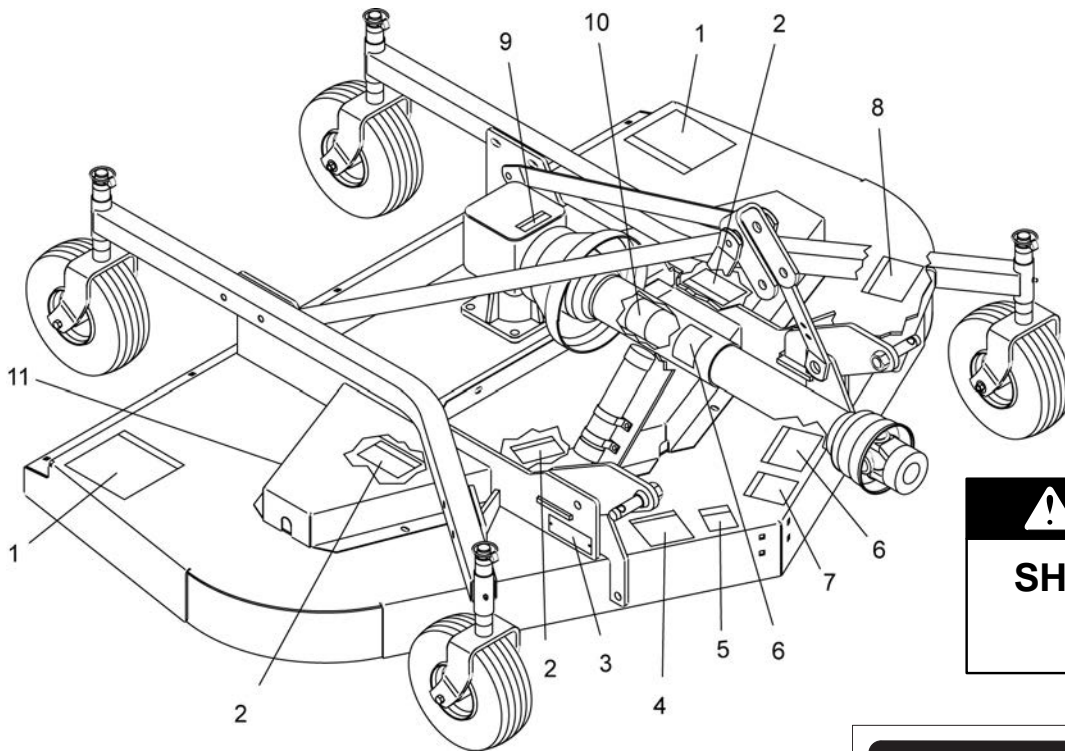

2 - 5WP18867

⚠ DANGER

SHIELD MISSING

DO NOT OPERATE
PUT SHIELD ON

18867-B

11 - 5WP20106 - Rear Reflector (GM3060 & GM3072 Only)

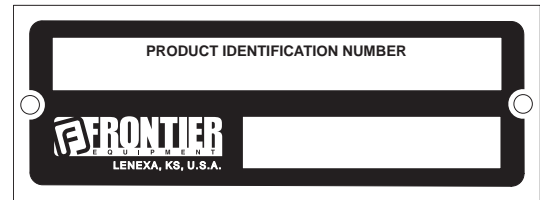

3 - Serial Number Plate

1 - 5WP15503

⚠ DANGER

**ROTATING BLADES AND
THROWN OBJECTS**

- Do not put hands or feet under or into mower when engine is running.
- Before mowing, clear area of objects that may be thrown by blade.
- Keep bystanders away.
- Keep guards in place and in good condition.

**BLADE CONTACT OR THROWN OBJECTS CAN
CAUSE SERIOUS INJURY OR DEATH.**

15503-C

4 - 5WP1003751

⚠ WARNING

CRUSHING AND PINCHING HAZARD

- Be extremely careful handling various parts of the machine. They are heavy and hands, fingers, feet, and other body parts could be crushed or pinched between tractor and implement.
- Operate tractor controls from tractor seat only.
- Do not stand between tractor and implement when tractor is in gear.
- Make sure parking brake is engaged before going between tractor and implement.
- Stand clear of machine while in operation or when it is being raised or lowered.

**FAILURE TO FOLLOW THESE
INSTRUCTIONS COULD RESULT IN
SERIOUS INJURY OR DEATH.**

1003751-A

(Safety Decals continued on next page)



SAFETY & INSTRUCTIONAL DECALS

ATTENTION! BECOME ALERT! YOUR SAFETY IS INVOLVED!
Replace Immediately If Damaged!



(Safety Decals continued from previous page)

! WARNING

**DO NOT EXCEED PTO SPEED OF
540 RPM**

PTO speeds higher than 540 RPM can cause equipment failure and personal injury.

18866-D

5 - 5WP18866

! WARNING

TO AVOID SERIOUS INJURY OR DEATH:

- Read Operator's Manual before operating, servicing or repairing equipment. Follow all safety rules and instructions. (Manuals are available from your selling dealer.)
- Never allow riders.
- Keep bystanders away from equipment during operation.
- Operate from tractor seat only.
- Keep all shields in place and in good condition.
- Lower equipment to ground, stop engine, remove key and set brake before dismounting tractor.
- Never allow children or untrained persons to operate equipment.
- Do not transport towed or semi-mounted units over 20 MPH.

FAILURE TO FOLLOW THESE INSTRUCTIONS CAN RESULT IN INJURY OR DEATH.

1002423-B

7 - 5WP1002423

! DANGER



**ROTATING DRIVELINE
CONTACT CAN CAUSE DEATH
KEEP AWAY!**

DO NOT OPERATE WITHOUT -

- All driveline guards, tractor and equipment shields in place
- Drivelines securely attached at both ends
- Driveline guards that turn freely on driveline

18864-C

6 - 5WP18864

! WARNING



FALLING OFF CAN RESULT IN BEING RUN OVER.

- Tractor must be equipped with ROPS (or ROPS CAB) and seat belt. Keep foldable ROPS systems in "locked up" position at all times.
- Buckle Up! Keep seat belt securely fastened.
- Allow no riders.

RAISED EQUIPMENT CAN DROP AND CRUSH.

- Before working underneath, follow all instructions and safety rules in operator's manual and securely block up all corners of equipment with jack stands.
- Securely blocking prevents equipment dropping from hydraulic leak-down, hydraulic system failures or mechanical component failures.

FALLING OFF OR FAILING TO BLOCK SECURELY CAN RESULT IN SERIOUS INJURY OR DEATH.

18865-C

8 - 5WP18865

! DANGER



**GUARD MISSING.
DO NOT OPERATE.**

! DANGER



**GUARD MISSING.
DO NOT OPERATE.**

33347E

! DANGER

10 - 5WP33347

9 - 5WP1004114

! DANGER

If shaft connection is visible, shield is missing. Replace shield before operating equipment.

1004114

BE CAREFUL!

Use a clean, damp cloth to clean safety decals.

Avoid spraying too close to decals when using a pressure washer; high-pressure water can enter through very small scratches or under edges of decals causing them to peel or come off.

Replacement safety decals can be ordered free from your dealer.

OPERATION

The operator is responsible for the safe operation of the mower. The operator must be properly trained. Operators should be familiar with the mower, the tractor, and all safety practices before starting operation. Read the safety rules and safety decals on page 5 through page 9.

This mower is designed for lawn and grass mowing. It is not designed for rough conditions or heavy weed mowing. It is equipped with suction type blades for best results in lawn mowing.

Recommended mowing speed for most conditions is from 2 to 5 mph.

! DANGER

■ Full chain shielding must be installed when operating in populated areas or other areas where thrown objects could injure people or damage property.

- If this machine is not equipped with full chain shielding, operation must be stopped when anyone comes within 300 feet (92 m).
- This shielding is designed to reduce the risk of thrown objects. The mower deck and protective devices cannot prevent all objects from escaping the blade enclosure in every mowing condition. It is possible for objects to ricochet and escape, traveling as much as 300 feet (92 m).

! WARNING

- Never allow children or untrained persons to operate equipment.
- Keep bystanders away from equipment.
- Make sure spring-activated locking pin or collar slides freely and is seated firmly in tractor PTO spline groove.
- Operate tractor PTO at 540 RPM. Do not exceed.
- Before working underneath, carefully read Operator's Manual instructions, disconnect driveline, raise mower, securely block up all corners with jackstands, and check stability. Secure blocking prevents equipment from dropping due to hydraulic leak down, hydraulic system failures, or mechanical component failures.
- Keep all persons away from operator control area while performing adjustments, service, or maintenance.

! CAUTION

- Stop power unit and implement immediately upon striking an obstruction. Dismount power unit, using proper procedure. Inspect and repair any damage before resuming operation.
- Always wear relatively tight and belted clothing to avoid entanglement in moving parts. Wear sturdy, rough-soled work shoes and protective equipment for eyes, hair, hands, hearing, and head; and respirator or filter mask where appropriate.

TRACTOR STABILITY

! WARNING

- A minimum 25% of tractor and equipment weight must be on the tractor front wheels when attachments are in transport position. Without this weight, tractor could tip over, causing personal injury or death. The weight may be attained with a loader. Weigh the tractor and equipment. Do not estimate.

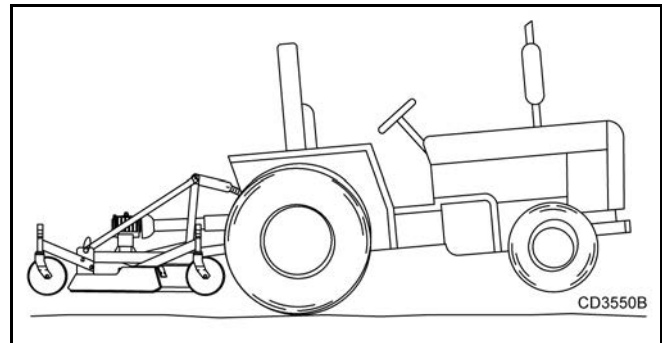

Figure 1. Tractor Stability

ATTACHING MOWER TO TRACTOR

! WARNING

- Make sure spring-activated locking pin or collar slides freely and is seated firmly in tractor PTO spline groove.

The standard 1-3/8" 6B-spline driveline with a QD yoke is used to connect the mower to the tractor.

1. Attach the mower hitch pins to the lower tractor lift arms and secure.
2. Attach tractor top link (1), Figure 2, to mower top link bracket attachment point (A). Connect the driveline to the tractor PTO shaft.
3. Attach tether chain to tractor drawbar (Figure 3).

- Adjust the tractor lower 3-point arm anti-sway devices to prevent mower from swinging side to side during transport.

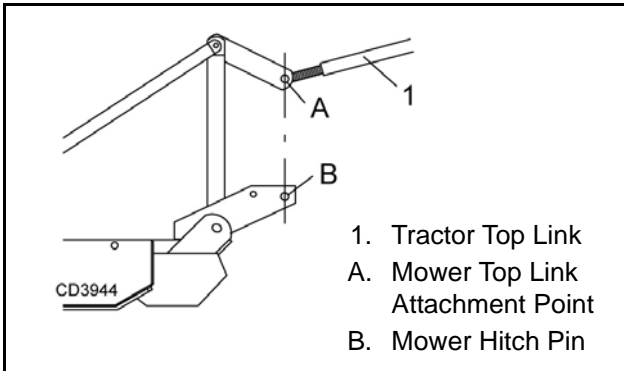

Figure 2. Attachment Points

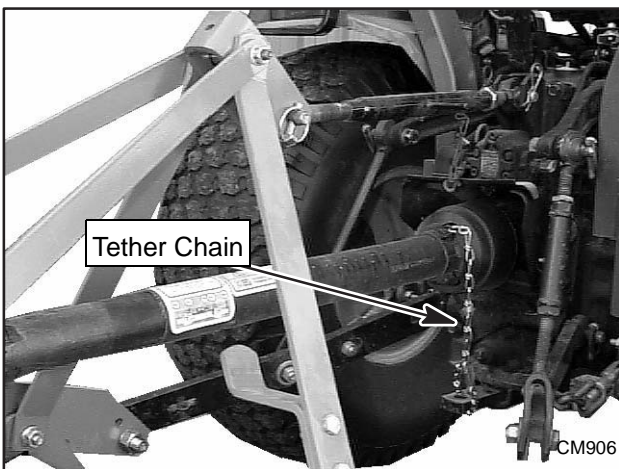

Figure 3. Attaching Mower to Tractor

CUTTING HEIGHT ADJUSTMENT

WARNING

- Keep all persons away from operator control area while performing adjustments, service, or maintenance.

NOTICE

- Avoid low cutting heights. Striking the ground with blades produces one of the most damaging shock loads a mower can encounter. Allowing blades to contact ground repeatedly will cause damage to mower and drive.

- Level mower from side to side. Check by measuring distance from mower frame to the ground at each deck rail.
- Verify that the same amount of spacers are under all caster arms.
- Control cutting height by adjusting front and rear caster wheels.

- To raise rear of mower, move caster adjustment spacers under rear caster arms.
- To raise front of mower, move spacers under front caster wheel arms.

Table 1: Cutting Height Chart

Spacers Required Under Caster Arm Pivot Tube		
Cut Height	1/2" Spacer	1" Spacer
1"	0	0
1-1/2"	1	0
2"	0	1
2-1/2"	1	1
3"	0	2
3-1/2"	1	2
4"	0	3
4-1/2"	1	3

TRACTOR TOP LINK ADJUSTMENT

When the cutting height is set, adjust tractor top link until mower top link attachment point (A), Figure 4, is aligned vertically with mower hitch pin (B). The front tires of the mower will lift off the ground before the rear tires when the unit is raised. This will allow the mower to follow the ground contour.

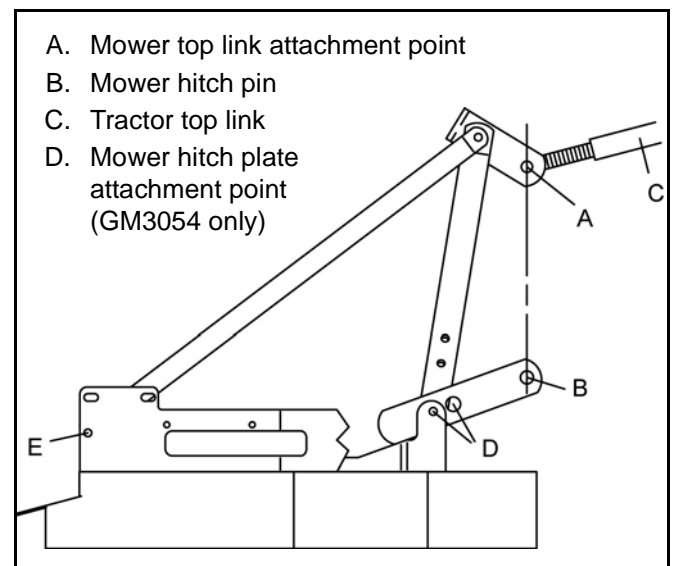

Figure 4. Top Link Adjustment

GM3054 Only

The GM3054 has two mower hitch plate attachment points (D). It may be necessary to change the mower hitch plate attachment point to obtain proper tire clearance and/or lift height.

FRONT CASTER WHEEL INTERFERENCE CHECK

NOTICE

■ **Do not operate tractor and mower until this interference check has been performed. If you change tractors, you must perform the check for that mounting.**

Perform this check with all of the spacers and springs above the caster wheel arm. This will place the caster wheels in their highest position and provide the lowest cutting height for the mower.

1. Raise mower with tractor hydraulics to 16" at dimension C, Figure 5, or maximum height of tractor lift, whichever is less.
2. Pivot both front caster wheels forward and check that there is clearance between caster wheels and tractor tires.
3. If there is interference on GM3054 model, adjust mower hitch plate point as shown in Figure 4. On model GM3060 and GM3072, the hitch plate is not adjustable; see tractor operator's manual and adjust tractor wheels accordingly.

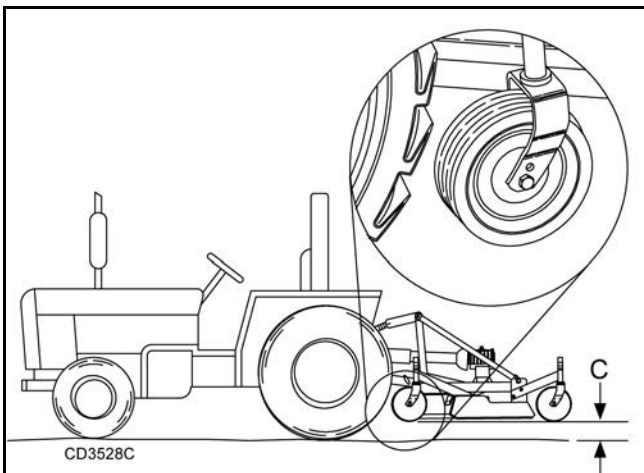

Figure 5. Front Caster Wheel Interference Check

FRONT ROLLER (OPTIONAL)

The caster wheels effectively reduce scalping in most cases. However, you may encounter areas where the caster wheels and/or side skids drop into depressions and allow center of the mower to contact ground and scalp. An optional front roller may be installed to minimize scalping. See page 40.

OPERATING TECHNIQUE

CAUTION

■ **Stop power unit and implement immediately upon striking an obstruction. Dismount power unit,**

using proper procedure. Inspect and repair any damage before resuming operation.

Power for operating the mower is supplied by the tractor PTO. Operate PTO at 540 rpm. Know how to stop tractor and mower quickly in an emergency.

If mower becomes plugged causing belt to slip for over two seconds, follow these steps:

1. Maneuver equipment into a previously cut area and allow mower to clear accumulated material.
2. Continue running at least two minutes, allowing pulleys to cool. Stopping the mower when in contact with a very hot pulley will bake and ruin belt.

Proper ground speed will depend upon the terrain, the height, and type and density of material to be cut.

Normally, ground speed will range from 2 to 5 mph. Tall dense material should be cut at a low speed; thin medium-height material can be cut at a faster ground speed. Always operate tractor PTO at 540 rpm to maintain proper blade speed and produce a clean cut.

Under certain conditions, tractor tires may roll some grass down and prevent it from being cut at the same height as the surrounding area. When this occurs, reduce your ground speed, but maintain PTO at 540 rpm. The lower ground speed will permit grass to partially rebound.

In general, lower cutting heights give a more even cut and leave less tire tracks. However, it is better to cut grass frequently rather than too short. Short grass deteriorates rapidly in hot weather and invites weed growth during growing seasons. Follow local recommendations for the suitable cutting height in your area.

Operating Tips

WARNING

■ **Inspect and clear area of stones, branches, or other hard objects that might be thrown, causing injury or damage.**

Extremely tall material should be cut twice. Set mower at a higher cutting height for the first pass. Then cut at desired height, 90 degrees to the first pass. Remember, sharp blades produce cleaner cuts and require less power.

Analyze area to be cut to determine the best procedure. Consider height and type of grass and terrain type: hilly, level, or rough. Plan your mowing pattern to travel straight forward whenever possible. Mow with uncut grass to the right. This will distribute the clippings over the cut area.

Uneven Terrain

WARNING

- Do not operate or transport on steep slopes.
- Do not stop, start, or change directions suddenly on slopes.
- Use extreme care and reduce ground speed on slopes and rough terrain.
- Watch for hidden hazards on the terrain during operation.

Pass diagonally through sharp dips and avoid sharp drops to prevent hanging up tractor and mower. Practice will improve your skills in maneuvering rough terrain.

REMOVING MOWER FROM TRACTOR - STORAGE

Follow cleaning procedure, page 17.

1. Disengage tractor PTO and raise mower with the 3-point hitch.
2. Disconnect mower driveshaft from tractor PTO.
3. Collapse driveshaft as far as possible and store it in PTO hanger bracket to prevent ground contact.
4. Place blocks under mower side skids. Lower mower onto blocks, disconnect mower from tractor 3-point hitch, and carefully drive tractor away from mower.

WARNING

- Keep children and bystanders away from storage area.

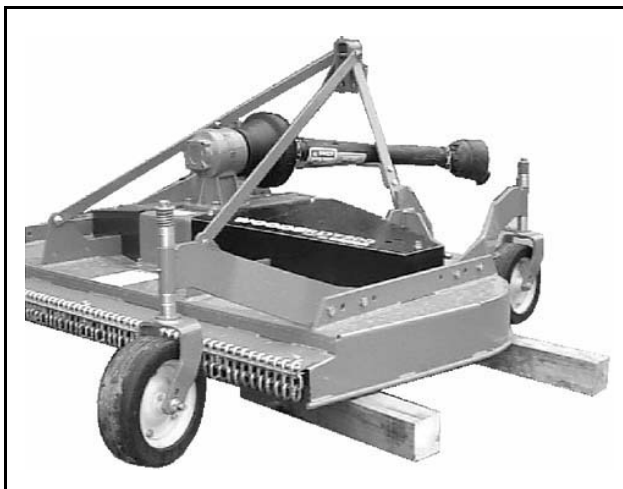

Figure 6. Mower Storage Position

OWNER PRE-OPERATION CHECK LIST

(OWNER'S RESPONSIBILITY)

- ___ Review and follow all safety rules and safety decal instructions on page 5 through page 9.
- ___ Check that all safety decals are installed and in good condition. Replace if damaged.
- ___ Check that all shields and guards are properly installed and in good condition. Replace if damaged.
- ___ Check that chain shielding is in good condition and replace any damaged chain links.
- ___ Check that all hardware and cotter pins are properly installed and secured.
- ___ Check to ensure blades are sharp, in good condition, and installed correctly. Replace if damaged.
- ___ Check that equipment is properly and securely attached to tractor.
- ___ Make sure driveline spring-activated locking pin or collar slides freely and is seated firmly in tractor PTO spline groove.
- ___ Make sure the driveline guards and tether chains are in good condition. Guards must rotate freely on driveline. Fasten tether chains to the tractor and the equipment as instructed.
- ___ Inspect area and remove stones, branches or other hard objects that might be thrown, causing injury or damage.
- ___ Do not allow riders.
- ___ Check all lubrication points and grease as instructed in Lubrication Information, page 14. Make sure the PTO slip joint is lubricated and that the gearbox fluid levels are correct.
- ___ Set tractor PTO at 540 rpm.
- ___ Make sure tractor ROPS or ROPS cab and seat belt are in good condition. Keep seat belt securely fastened during operation.
- ___ Before starting engine, operator must be in tractor seat with seat belt fastened. Place transmission in neutral or park, engage brake, and disengage tractor PTO.

OWNER SERVICE

The information in this section is written for operators who possess basic mechanical skills. If you need help, your dealer has trained service technicians available. For your protection, read and follow the safety information in this manual.

WARNING

- Never allow children or untrained persons to operate equipment.
- Keep bystanders away from equipment.
- Before working underneath, carefully read Operator's Manual instructions, disconnect driveline, raise mower, securely block up all corners with jackstands, and check stability. Secure blocking prevents equipment from dropping due to hydraulic leak down, hydraulic system failures, or mechanical component failures.
- Keep all persons away from operator control area while performing adjustments, service, or maintenance.
- Make sure spring-activated locking pin or collar slides freely and is seated firmly in tractor PTO spline groove.
- Operate tractor PTO at 540 RPM. Do not exceed.

CAUTION

- Always wear relatively tight and belted clothing to avoid entanglement in moving parts. Wear sturdy, rough-soled work shoes and protective equipment for eyes, hair, hands, hearing, and head; and respirator or filter mask where appropriate.

BLOCKING METHOD

Do not work underneath mower unless it is properly attached to the tractor and blocked securely. When properly attached, the unit will be anchored to minimize front to rear movement.

Raise mower completely, set tractor brakes, turn engine off, remove key, block tractor wheels front and rear, and disconnect mower driveline from tractor.

The only approved blocking devices for this mower are jackstands with a load rating of 1000 pounds or more. One jackstand under each corner of the mower (four total) must be installed before working underneath this unit.

When blocking, you must consider overall stability of the unit. Just blocking under the unit will not ensure your safety. The working surface must be level and solid to support the loaded weight of the jackstands. Test jackstand stability before working under any portion of the mower.

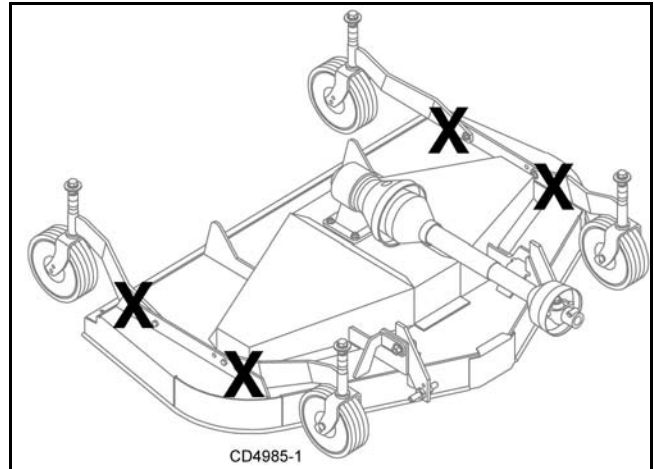

Figure 7. Jackstand Placement

LUBRICATION INFORMATION

Do not let excess grease collect on or around parts, particularly when operating in sandy areas.

Figure 8 shows the lubrication points. The accompanying chart gives the frequency of lubrication in operating hours, based on normal operating conditions.

Severe or unusual conditions may require more frequent lubrication. Some reference numbers have more than one location; be sure you lubricate all locations.

Use a lithium grease of #2 consistency with a MOLY (molybdenum disulfide) additive for all locations. Be sure to clean fittings thoroughly before attaching grease gun. When applied according to the lubrication chart, one good pump of most guns is sufficient.

Use SAE 80W or 90W gear lube in the gearbox. Fill to plug on side of gearbox.

Check gearbox daily for evidence of leakage at both seals and the gasket between the housing and cover. If leakage is noted, repair immediately. There may be a small amount of lube emitted from the vent plug; this is not considered leakage.

Overfilling the gearbox will cause the excess gear lube to blow out vent plug and ruin the belt.

Driveshaft Lubrication

Lubricate the driveshaft slip joint every 40 operating hours. Failure to maintain proper lubrication could result in damage to U-joints, gearbox, and driveshaft.

1. Lower mower to ground.

2. Remove front half of driveshaft.

3. Apply grease all around and along inner shaft.

4. Reassemble driveshaft halves.

5. Raise and lower mower several times to distribute grease.

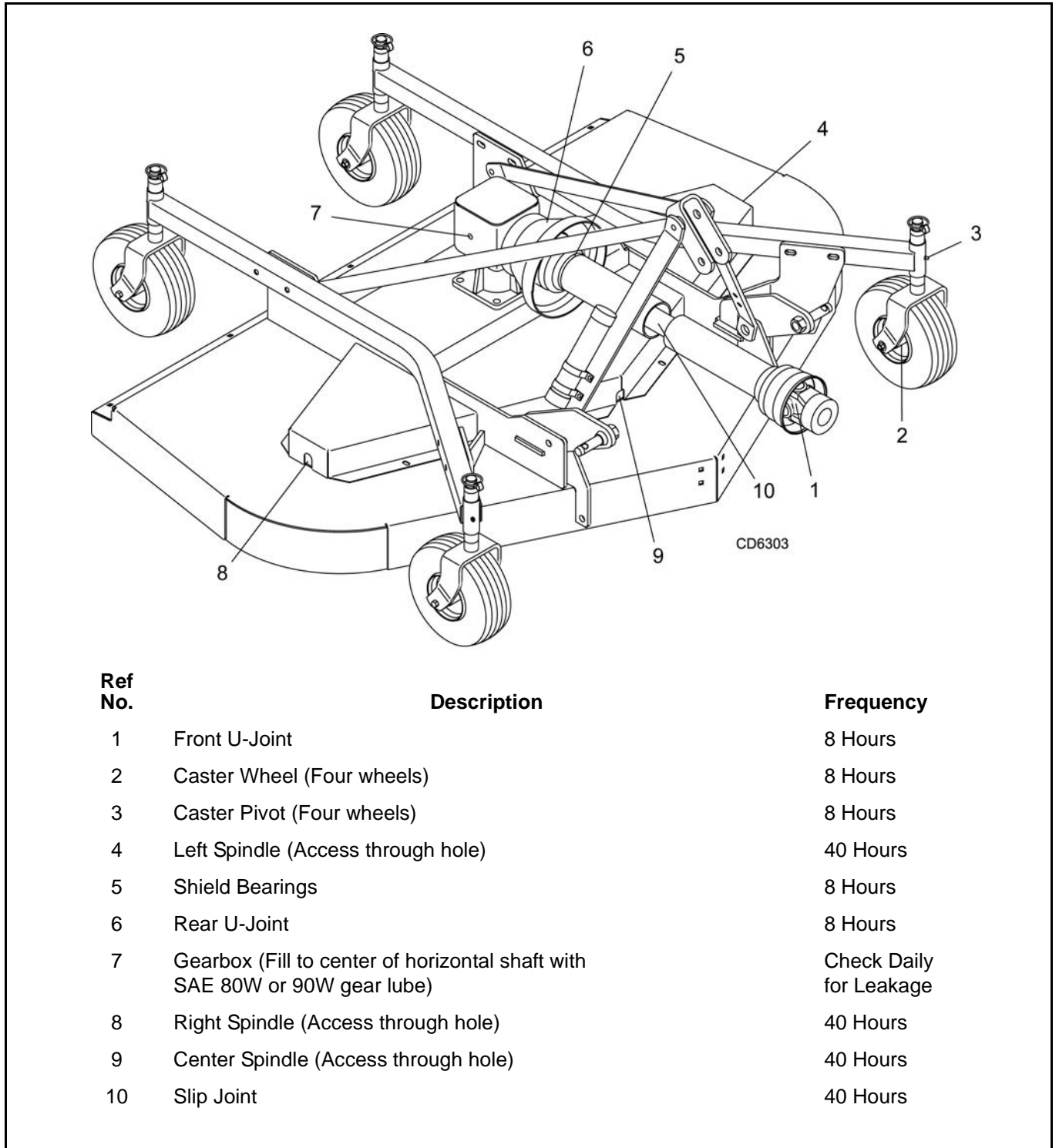

Figure 8. Lubrication Points & Chart

BELT SERVICE

Belt Replacement

One of the major causes of belt failure is improper installation. Before installing a new belt, check the following:

1. Check pulley shafts and bearings for wear.
2. Check pulley grooves for cleanliness.
3. Make sure spindles turn freely and without wobble.

If grooves require cleaning, moisten a cloth with a non-flammable, non-toxic degreasing agent or commercial detergent and water.

Avoid excessive force during installation. Do not use tools to pry belt into pulley groove. Do not roll belt over pulleys to install. This can cause hidden damage and premature belt failure.

Belt Installation

Refer to Figure 9.

CAUTION

- Use care when installing or removing belt from spring-loaded idler. Springs store energy when extended and, if released suddenly, can cause personal injury.

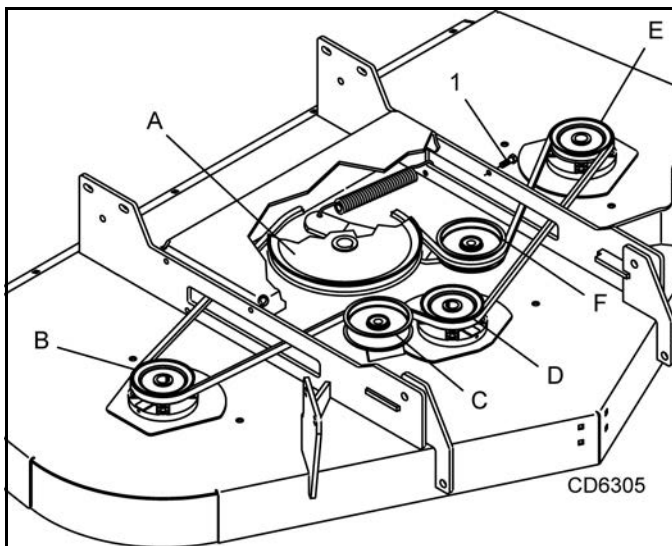

Figure 9. Belt Routing

1. Slide belt under drive pulley A and over idler arm. Position belt around drive pulley A.
2. It may be necessary to remove front bolts (1) and swing gearbox stand up to gain access to pulley A. Route belt around pulley B, idler C, and pulley D as shown.

3. Make sure belt is on drive pulley A and route around idler F.
4. Grasp belt between spindle pulley E, spring-loaded idler F and spindle pulley D. Pull spring-loaded idler with belt to obtain enough belt length to route it over pulley E. Make sure spring-loaded idler pivots freely with belt installed.

BLADE SERVICE

WARNING

- Before dismantling power unit or performing any service or maintenance, follow these steps: disengage power to equipment, lower the 3-point hitch and all raised components to the ground, operate valve levers to release any hydraulic pressure, set parking brake, stop engine, remove key, and unfasten seat belt.

- Keep all persons away from operator control area while performing adjustments, service, or maintenance.

CAUTION

- Frequently check blades. They should be sharp, free of nicks and cracks, and securely fastened.

1. Inspect blades before each use to determine that they are mounted securely and are in good condition.
2. Replace any blade that is bent, excessively nicked, worn, or has any other damage.
3. Small nicks can be ground out when sharpening.

Blade Removal

WARNING

- Do not handle blades with bare hands. Careless or improper handling may result in serious injury.

1. Remove bolt (1), Figure 11, which has right hand threads.
2. Remove washer and blade.

Blade Sharpening

NOTICE

- When sharpening blades, be sure to balance them. Unbalanced blades will cause excessive vibration that can damage blade spindle bearings. Vibration may also cause structural cracks in mower housings.

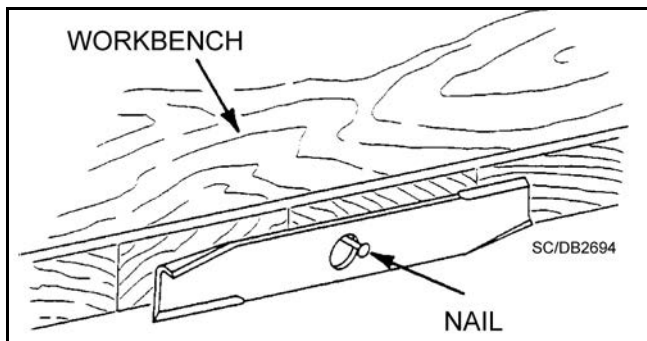

Figure 10. Blade Balancing

1. Follow original sharpening pattern.
2. Do not sharpen blade to a razor edge, but leave approximately 1/64" blunt edge.
3. Do not sharpen back side of blade.
4. Sharpen both cutting edges equally to keep blade balanced. Balance blade using the method shown in Figure 10.

Blade Installation

CAUTION

■ Your dealer can supply genuine replacement blades. Substitute blades may not meet original equipment specifications and may be dangerous.

NOTICE

■ When installing blade, the lift of the blade must be toward the spindle blade housing as shown in Figure 11. Torque bolt (1) into shaft assembly to 100 lbs-ft.

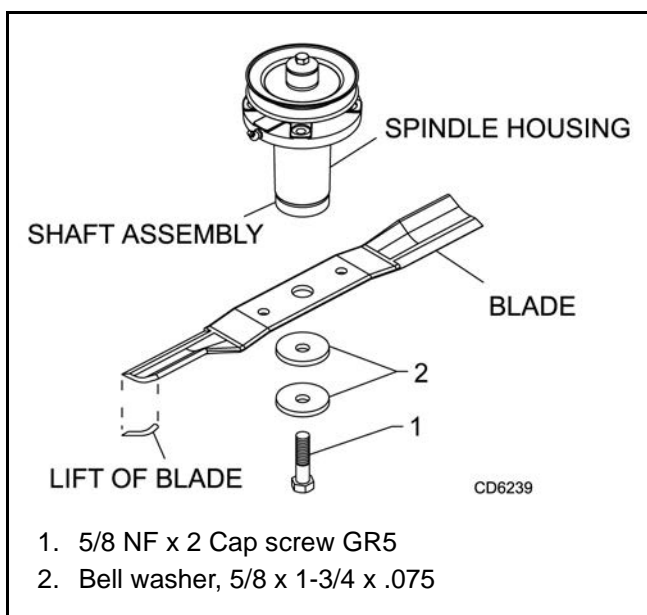

Figure 11. Blade and Spindle Assembly

1. Place blade over blade pilot on the bottom of the shaft assembly.
2. Place bell washer (2) over blade and insert blade bolt (1). Torque blade bolt to 100 lbs-ft.

CHAIN SHIELDING

! DANGER

■ Full chain shielding must be installed when operating in populated areas or other areas where thrown objects could injure people or damage property.

- If this machine is not equipped with full chain shielding, operation must be stopped when anyone comes within 300 feet (92 m).
- This shielding is designed to reduce the risk of thrown objects. The mower deck and protective devices cannot prevent all objects from escaping the blade enclosure in every mowing condition. It is possible for objects to ricochet and escape, traveling as much as 300 feet (92 m).

Check that chain shielding is in good condition and replace any damaged chain links.

CLEANING

After Each Use

- Remove large debris such as clumps of dirt, grass, crop residue, etc. from machine.
- Inspect machine and replace worn or damaged parts.
- Replace any safety decals that are missing or not readable.

Periodically or Before Extended Storage

- Clean large debris such as clumps of dirt, grass, crop residue, etc. from machine.
- Remove the remainder using a low-pressure water spray.
 1. Be careful when spraying near scratched or torn safety decals or near edges of decals as water spray can peel decal off surface.
 2. Be careful when spraying near chipped or scratched paint as water spray can lift paint.
 3. If a pressure washer is used, follow the advice of the pressure washer manufacturer.
- Inspect machine and replace worn or damaged parts.
- Sand down scratches and the edges of areas of missing paint and coat with spray paint of matching color (purchase from your dealer).
- Replace any safety decals that are missing or not readable (supplied free by your dealer). See Safety Decals section for location drawing.

TROUBLESHOOTING

MOWING CONDITIONS

PROBLEM	POSSIBLE CAUSE	SOLUTION
Grass cut higher in center of swath than at edge	Height of mower higher at front than at rear	Adjust mower height and attitude so that mower rear and front are within 1/2 inch of same height. See instructions on page 11.
	Loose blade	Check blade hardware.
Grass cut lower in center of swath than at edge	Height of mower lower at front than at rear	Adjust mower height and attitude so that mower rear and front are within 1/2 inch of same height. See instructions on page 11.
	Loose blade	Check blade hardware.
Streaking conditions in swath	Conditions too wet for mowing	Allow grass to dry before mowing.
	Blades unable to cut that part of grass pressed down by path of tractor tires	Slow ground speed of tractor but keep engine running at full PTO rpm. Cutting lower will help. Adjust tractor tire spacing if possible.
	Dull blades	Sharpen or replace blades.
Material discharges from mower unevenly; bunches of material along swath	Loose blade	Check blade hardware.
	Material too high and too much material	Reduce ground speed but maintain 540 rpm at tractor PTO, or make two passes over material. Raise mower for the first pass and lower for the second and cut 90-degrees to first pass. Raise rear of mower high enough to permit material discharge, but not so high that conditions listed above occur.
	Grass is wet	Allow grass to dry before mowing. Slow ground speed of tractor but keep engine running at full PTO rpm.

TROUBLE SHOOTING

BELT CONDITIONS

PROBLEM	POSSIBLE CAUSE	SOLUTION
Belt slippage	Mower overloading; material too tall or heavy	Reduce tractor ground speed but maintain full PTO rpm. Cut material twice, one high pass and then mow at desired height. Cut at 90 degrees to first pass.
	Oil on belt from over lubricating	Be careful not to over lubricate. Clean lubricant from belt and pulleys with clean rag. Replace oil-soaked belt.
	Belt hung up or rubbing	Check belt position in pulleys and idlers. Check belt for free travel in pulleys. Check under mower and around blade spindle shaft for wire, rags, or other foreign material. Clean all material from under mower.
Frayed edges on belt cover	Belt is misaligned	Re-align belt. Be sure belt does not rub any other part while running.
	Pulley is misaligned	Inspect to ensure belt is running in center of backside idler. Shim idler as necessary to align.
Belt rollover	Pulley is misaligned	Re-align.
	Damaged belt	Replace belt. *
	Foreign object in pulley groove	Inspect all pulley grooves for rust, paint, or weld spots and remove.
	Worn pulley groove	Replace pulley.
Damaged belt	Rollover, high shock loads or installation damaged	Replace belt. *
Belt breakage	High shock loads	Avoid abusive mowing. Avoid hitting the ground or large obstructions.
	Belt came off drive	Check pulleys for foreign material in grooves. Avoid hitting solid objects or ground.

* Check belt for damage by laying it flat on the floor. A belt that does not lie flat (has humps or twists, indicating broken or stretched cords) must be replaced.

DEALER SERVICE

The information in this section is written for dealer service personnel. The repair described here requires special skills and tools. If your shop is not properly equipped or your mechanics are not properly trained in this type of repair, you may be time and money ahead to replace complete assemblies.

⚠ WARNING

■ Before working underneath, read manual instructions, securely block up, and check stability. Secure blocking prevents equipment from dropping due to hydraulic leak down, hydraulic system failure, or mechanical component failure.

■ Keep all persons away from operator control area while performing adjustments, service, or maintenance.

⚠ CAUTION

■ Always wear relatively tight and belted clothing to avoid entanglement in moving parts. Wear sturdy, rough-soled work shoes and protective equipment for eyes, hair, hands, hearing, and head; and respirator or filter mask where appropriate.

BLOCKING METHOD

See instructions on page 14.

BLADE SPINDLE REPAIR

Spindle repair requires special skills and tools. If your shop is not properly equipped or your mechanics are not trained in this type of repair, you may be time and money ahead to use a new spindle assembly.

For reference, the grease fitting is in the top of the spindle shaft.

Permatex® 3D Aviation Form-A-Gasket or equivalent is recommended as a sealant.

Remove Spindle

1. Remove belt shields from deck.
2. Remove belt.
3. Remove blade from spindle assembly.
4. Remove nuts (6) and bolts (9) that secure spindle to mower. (See Figure 12.)

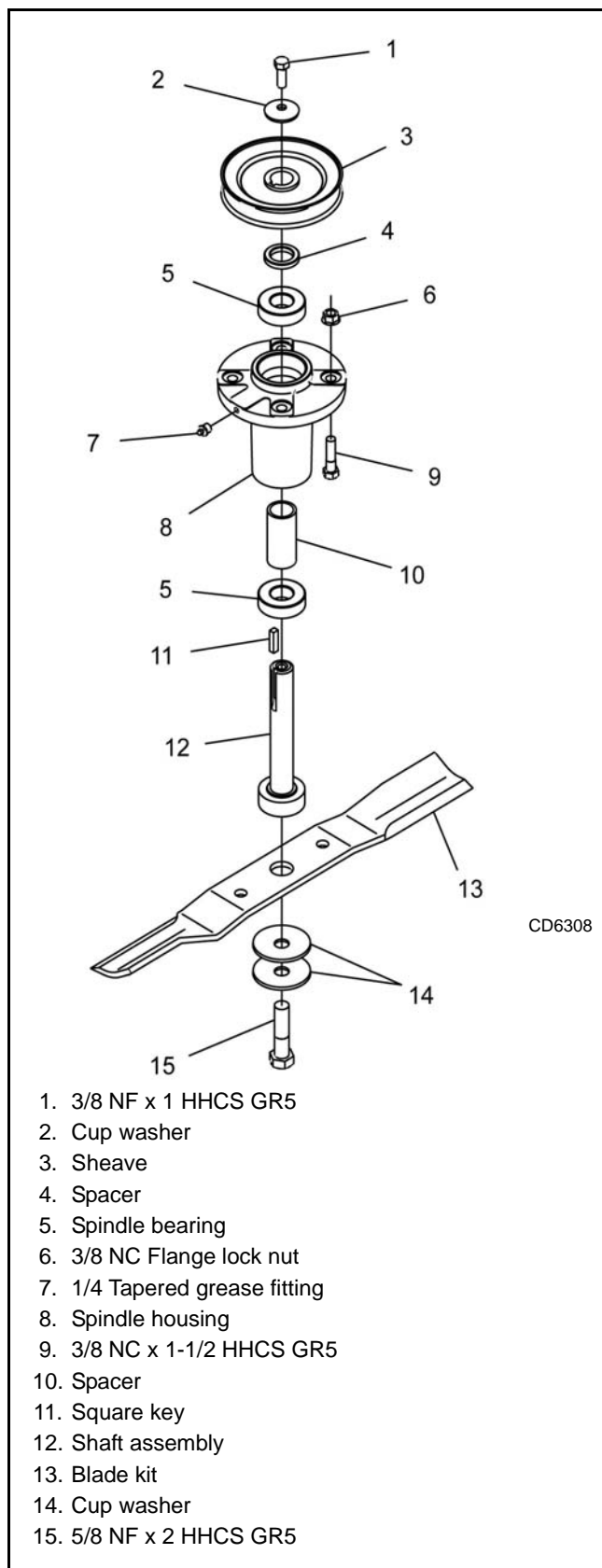

Figure 12. Blade Spindle Assembly

Disassemble Spindle

1. Remove bolt (1) and washer (2) from the top of the spindle.
2. Remove sheave (3) and spacer (4).
NOTE: A wheel puller may be needed if sheave can not be removed by hand. Retain key (11).
3. Slide shaft assembly (12), lower bearing (5), and long spacer (10) out the bottom of spindle housing (8).
4. Remove upper bearing (5) and spacer (4) from top of spindle housing.
5. Inspect parts and replace as needed.

Assemble Spindle

1. Slide lower bearing (5) over shaft assembly (12) with seal down.
2. Slide long spacer (10) on shaft assembly.
3. Insert shaft assembly with bearing and spacer into spindle housing from the bottom.
4. Install upper bearing (5) over shaft with the seal facing up.
5. Install spacer (4) and sheave (3) over shaft.
6. Align keyways in shaft and sheave and insert key (11).
7. Install washer (2), and bolt (1). Torque bolt to 35 lbs-ft.
8. Rotate sheave and check for free movement.
9. Lubricate spindle.

GEARBOX REPAIR

Read this entire section before starting any repair. Many steps are dependent on each other.

Fill gearbox with SAE 80W or 90W gear lube until it runs out the side level plug.

Repair to this gearbox is limited to replacing bearings, seals, and gaskets. Replacing gears, shafts, and a housing is not cost effective. It is more economical to purchase a complete gearbox if repair to anything other than replacement of bearings, seals or gaskets is required.

Inspect gearbox for leakage and bad bearings.

Leakage is a very serious problem and must be corrected immediately.

Bearing failure is indicated by excessive noise and side to side or end play in gear shafts.

Seal Replacement

Recommended sealant for gearbox repair is Permatex[®] Aviation 3D Form-A-Gasket or equivalent.

Leakage can occur at the vertical or horizontal gaskets and shaft seals.

Leakage at the horizontal gasket or seal can be repaired without removing the gearbox from the mower.

Seal Installation

NOTE: Proper seal installation is important. An improperly installed seal will leak.

1. Clean area in housing where seal outer diameter (OD) seats. Apply a thin coat of Permatex.
2. Inspect area of shaft where seal seats. Remove any burrs or nicks with an emery cloth.
3. Lubricate gear shaft and seal lips.
4. Place seal squarely on housing, spring-loaded lip toward housing. Select a piece of pipe or tubing with an OD that will sit on the outside edge of the seal but will clear the housing. Tubing with an OD that is too small will bow seal cage and ruin seal.
5. Carefully press seal into housing, avoiding distortion to the metal seal cage.

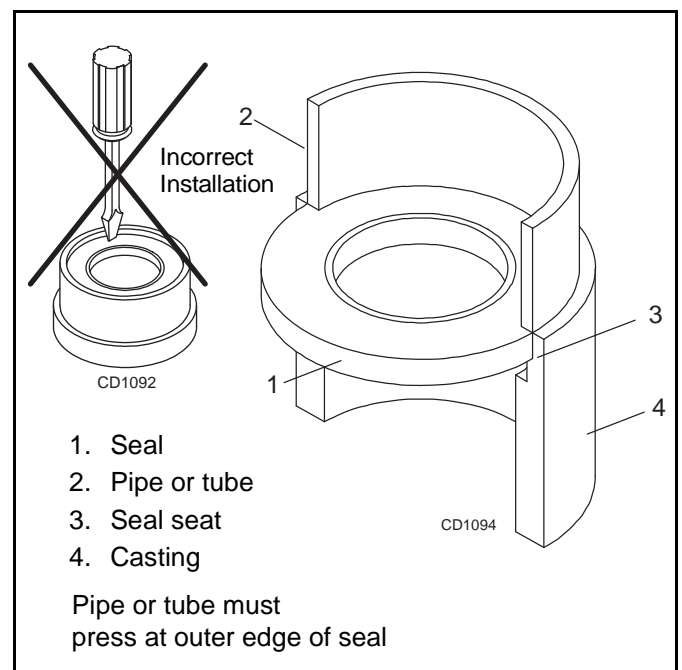

Figure 13. Seal Installation

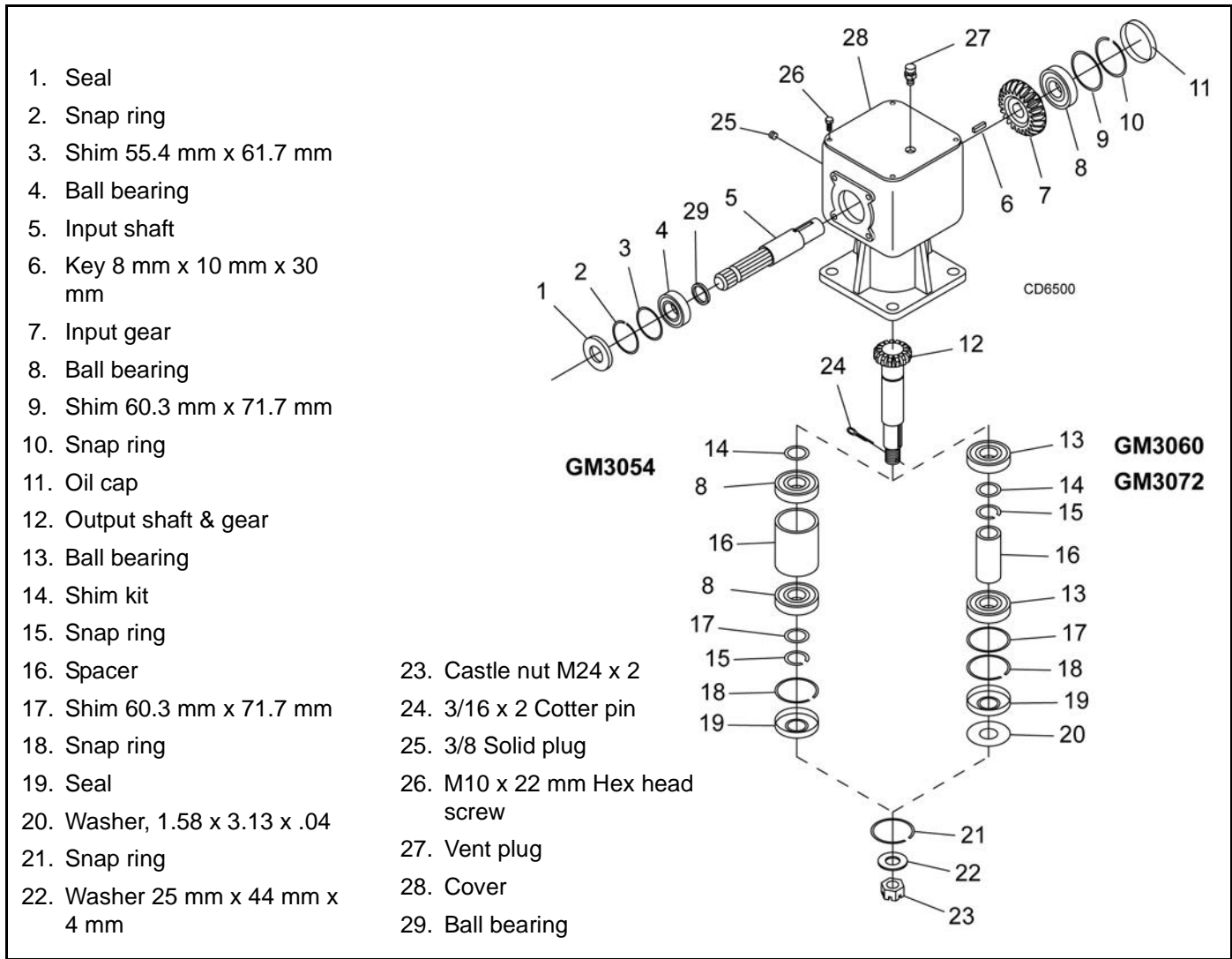

Figure 14. Gearbox Assembly

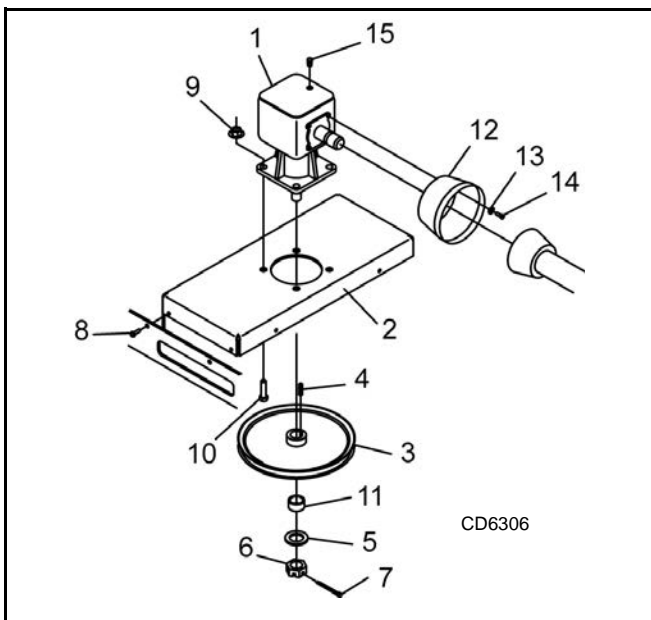

Figure 15. Gearbox Stand Assembly

Vertical Shaft Seal Replacement (Figure 15)

1. Disconnect and remove the driveline from the gearbox.
2. Remove vent plug (15) and siphon gear lube from housing through this opening.
3. Remove gearbox stand from mower deck.
4. Remove gearbox and pulley from stand (2).
5. Remove vertical shaft seal. Replace with new seal (see Seal Replacement, page 21).

Vertical seal should be recessed in housing. Horizontal seal should be pressed flush with outside of housing.

NOTE: Distortion to seal cage or damage to seal lip will cause seal to leak.

6. Fill gearbox with SAE 80W or 90W gear lube until it runs out the level plug.
7. Assemble gearbox and pulley to gearbox stand. Attach gearbox stand to mower deck.

Horizontal Shaft Seal Replacement

1. Disconnect and remove the driveline from the gearbox.
2. Remove vent plug (27), Figure 14, and siphon gear lube from housing through this opening.
3. If the leak occurred at either end of horizontal shaft, remove oil cap (11) and/or oil seal (1). Replace with new one (see Seal Replacement, page 21).
4. Fill gearbox with SAE 80W or 90W gear lube until it runs out the level plug.

Remove Gearbox from Mower

1. Disconnect and remove the rear driveline from the gearbox.
2. Remove vent plug (15), Figure 15, and siphon gear lube from housing through this opening.
3. Remove gearbox stand (2) from mower deck by removing four hex screws (8).
4. Remove four cap screws (14) and washers (13) and remove shield (12) from gearbox.
5. Remove castle nut (6) and hardware from output shaft of gearbox.
6. Remove sheave (3) from gearbox.
7. Remove four bolts (10) that attach gearbox to gearbox stand and remove gearbox.

Disassemble Gearbox

1. Remove top cover (28), Figure 14, from housing. Turn gearbox upside down and pour out remaining gear oil from gearbox.
2. Remove oil cap (11) (to be replaced).
3. Remove snap ring (10) and shim (9) from input shaft (5).
4. Support gearbox in hand press and push on input shaft (5) to remove bearing (8).
5. Remove gear (7) from inside housing.
6. Remove oil seal (1) from front of housing (to be replaced).
7. Remove snap ring (2) and shim (3) from front of housing.
8. Remove input bearing (4) by using a punch and hammer from outside of housing.
9. Support housing in vise in a horizontal position.
10. The castle nut (23) and cotter pin (24) are already removed with the drive sheave. Remove the snap ring (18), washer (20), and seal (19).
11. Remove output shaft (12) and bearings by using a punch and hammer and tap on top to drive down.

12. Inspect gears for broken teeth and wear. Some wear is normal and will show on laded side. Forged gear surfaces are rough when new. Check that wear pattern is smooth.
13. Inspect vertical and horizontal shafts for grooves, nicks, or bumps in the areas where the seals seat. Resurface any damage with emery cloth.
14. Inspect housing and caps for cracks or other damage.

Reassemble Gearbox

(GM3060, GM3072 shown, GM3054 similiar)

Refer to Figure 14.

NOTE: Repair to this gearbox is limited to replacing bearings, seals, and gaskets. Replacing gears, shafts, and a housing is not cost effective. Purchasing a complete gearbox is more economical.

1. Clean housing, paying special attention to areas where seals will be installed.
2. Wash housing and component thoroughly. Select a clean area for gearbox assembly. Replace all seals and bearings. All parts must be clean and lightly oiled before reassembling.

GM3060 & GM3072

3. Install upper output bearing (13), shims (14), and snap ring (15) on output shaft (12). Use new shims equal to the thickness of the original shims.
4. Press output shaft assembly into housing from the bottom opening.
5. Install spacer (16), lower output bearing (13), shims (17), and snap ring (18) in bottom of housing.

GM3054

1. Install shims (14), upper output bearing (8), spacer (16), lower output bearing (8), shims (17), and snap ring (15) on output shaft. Use new shims equal to the thickness of the original shims.
2. Press output shaft assembly into housing from the bottom opening.
3. Install snap ring (18) in bottom of housing.

All Models

4. Apply grease to lower seal lips (19), and press seal over output shaft (5), using a round tube of the correct diameter. Be sure not to damage the seal lip. Press in housing so that the seal is recessed.
5. Insert protective washer (20) (GM3060 & GM3072 only) by hand.
6. Install snap ring (21) and position it together with seal (19) by pressing it into position. Verify that the snap ring is seated properly.

7. Press bearing (8) into the housing, using a round tube of the correct diameter and a hand press. Secure with shims (9) and snap ring (10).
8. Install key (6) on input shaft (5).
9. Place gear (7) through top of housing and align the two gears so they match.
10. While holding gear (7) in place, slide input shaft (5) through the gear and bearing (8).
11. Slide spacer (29) (GM3054 only) and bearing (4) over input shaft (5) and press into housing, using a round tube of the correct diameter and a hand press.
12. Slide shim (3) over input shaft and secure with snap ring (2).
13. Check input shaft end float by moving the input shaft by hand. If the end float is more than .012", insert shim (9) between the rear bearing (8) and snap ring (10).
14. Check that gear backlash is between .006" and .016". You should not have to adjust the backlash.
15. Press in input seal (1), using a round tube of the correct diameter. Be careful not to damage the seal lip.
16. Press oil cap (11) on to the rear cover of housing, using a round tube of the correct diameter.
17. Check the gearbox housing for leaks by plugging all holes except one. Apply 4 psi compressed air and immerse the gearbox in water to verify that there are no leaks.
18. Remove the gearbox from water and dry off with compressed air. Add SAE 80W or 90W EP oil until it runs out of the side level hole. Tighten all plugs.

Install Gearbox

NOTE: Gearbox is heavy: do not attempt to move without mechanical assistance.

1. Set gearbox on gearbox stand and fasten with bolts and nuts. Torque bolts to 175 lbs-ft.
2. Attach drive sheave to output shaft. Secure using castle nut and hardware previously removed.
3. Attach gearbox stand to mower using four hex screws.

Install Drive Sheave

1. When gear stand is installed on mower, dimension A (from the top of the mower deck to the center line of the drive pulley) must be 2-1/16" ($\pm 1/32"$). This is a critical dimension and must be carefully adjusted

for proper belt life. Add or subtract shim washers under idler pulley to align with drive pulley.

2. Tighten gear stand hardware.
3. Fill gearbox half full with SAE 80W or 90W gear lube.
4. Check level after waiting five minutes to permit lube to work through bearings. Add lube, if necessary, until gearbox is half full.
5. Replace driveline shield. Attach driveline to gearbox.

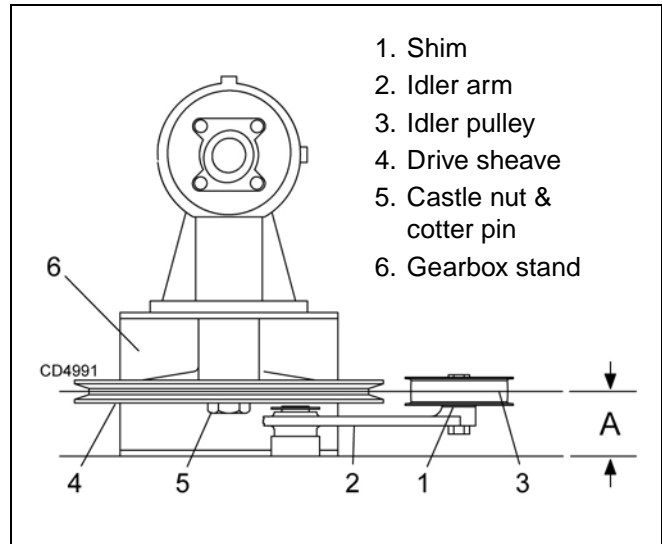

Figure 16. Drive Sheave Installation

UNIVERSAL JOINT REPAIR

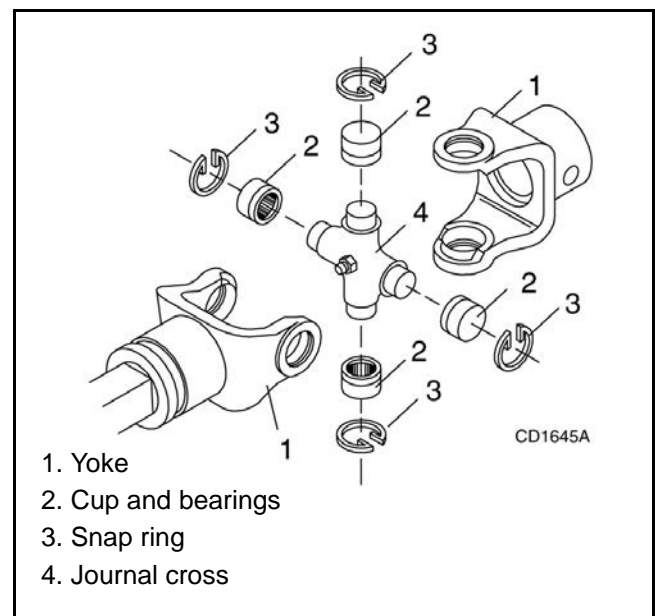

Figure 17. U-Joint Exploded View

U-Joint Disassembly

1. Remove external snap rings from yokes in four locations as shown in Figure 18.

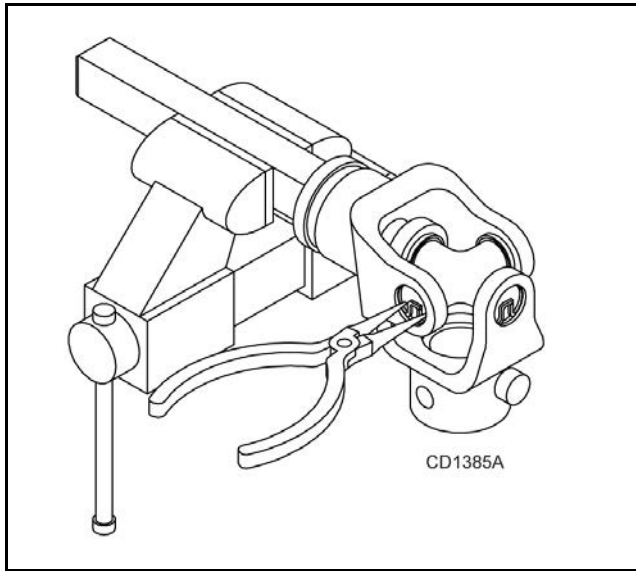

Figure 18

2. With snap rings removed, support drive in vise, hold yoke in hand and tap on yoke to drive cup up out of yoke. See Figure 19.

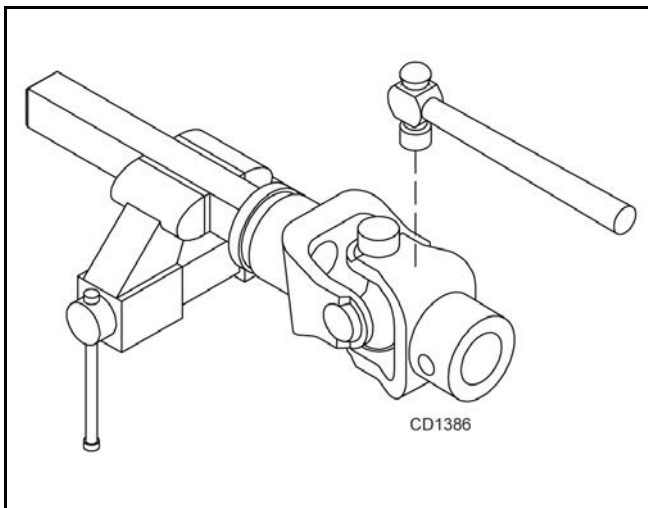

Figure 19

3. Clamp cup in vise as shown in Figure 20 and tap on yoke to completely remove cup from yoke. Repeat Step 2 and Step 3 for opposite cup.

4. Place universal cross in vise as shown in Figure 21 and tap on yoke to remove cup. Repeat Step 3 for final removal. Drive remaining cup out with a drift and hammer.

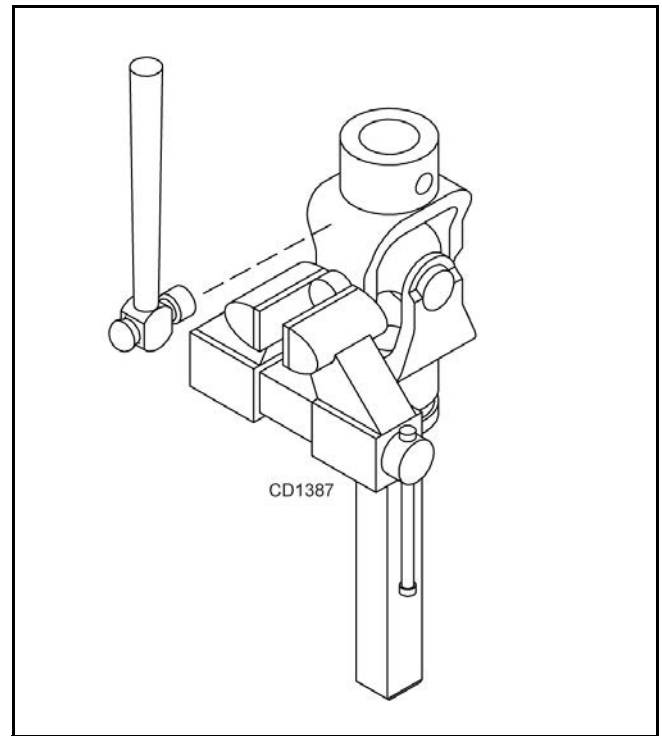

Figure 20

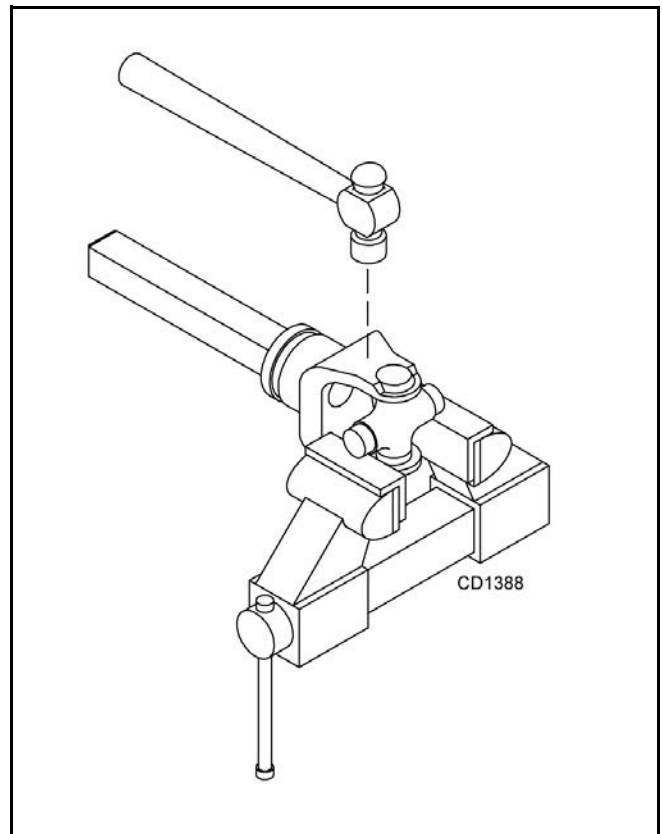

Figure 21

U-Joint Assembly

1. Place seals securely on bearing cups. Insert cup into yoke from outside and press in with hand pressure as far as possible. Insert journal cross into bearing cup with grease fitting away from shaft. Be careful not to disturb needle bearings. Insert another bearing cup directly across from first cup and press in as far as possible with hand pressure.
2. Trap cups in vise and apply pressure. Be sure journal cross is started into bearings and continue pressure with vise, squeezing in as far as possible. Tapping the yoke will help.
3. Seat cups by placing a drift or socket (slightly smaller than the cup) on cup and rap with a hammer. See Figure 22. Install snap ring and repeat on opposite cup.
4. Repeat Step 1 & Step 2 to install remaining cups in remaining yoke.
5. Move both yokes in all directions to check for free movement. If movement is restricted, rap on yokes sharply with a hammer to relieve any tension. Repeat until both yokes move in all directions without restriction.

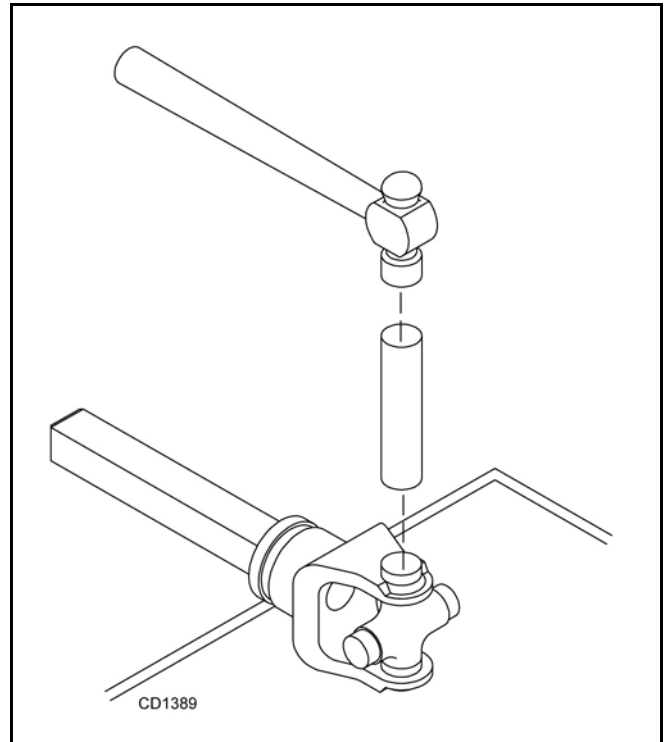

Figure 22



ASSEMBLY INSTRUCTIONS

DEALER SET-UP INSTRUCTIONS

Assembly of this mower is the responsibility of the dealer. It should be delivered to the owner completely assembled, lubricated, and adjusted for normal cutting conditions.

Complete Dealer Check Lists on page 31 when you have completed the assembly.

The mower is shipped partially assembled. Assembly will be easier if components are aligned and loosely assembled before tightening hardware. Recommended torque values for hardware are located on page 42.

Select a suitable working area. Open parts boxes and lay out parts and hardware to make location easy. Refer to illustrations, accompanying text, parts lists and exploded view drawings.

WARNING

■ Before working underneath, carefully read Operator's Manual instructions, disconnect driveline, raise mower, securely block up all corners with jackstands, and check stability. Secure blocking prevents equipment from dropping due to hydraulic leak down, hydraulic system failures, or mechanical component failures.

CAUTION

■ Always wear relatively tight and belted clothing to avoid entanglement in moving parts. Wear sturdy, rough-soled work shoes and protective equipment for eyes, hair, hands, hearing, and head; and respirator or filter mask where appropriate.

Uncrate Mower

1. Remove sides and top of mower shipping crate.
2. Remove lag screws and brackets that secure mower to crate base.
3. Remove driveshaft wired to mower deck.

Install A-Frame Arms

1. Loosen lock nuts (52) at lower hitch point and install A-frame arms (13) as shown.
2. Tighten nut securely.
3. Repeat for opposite side.

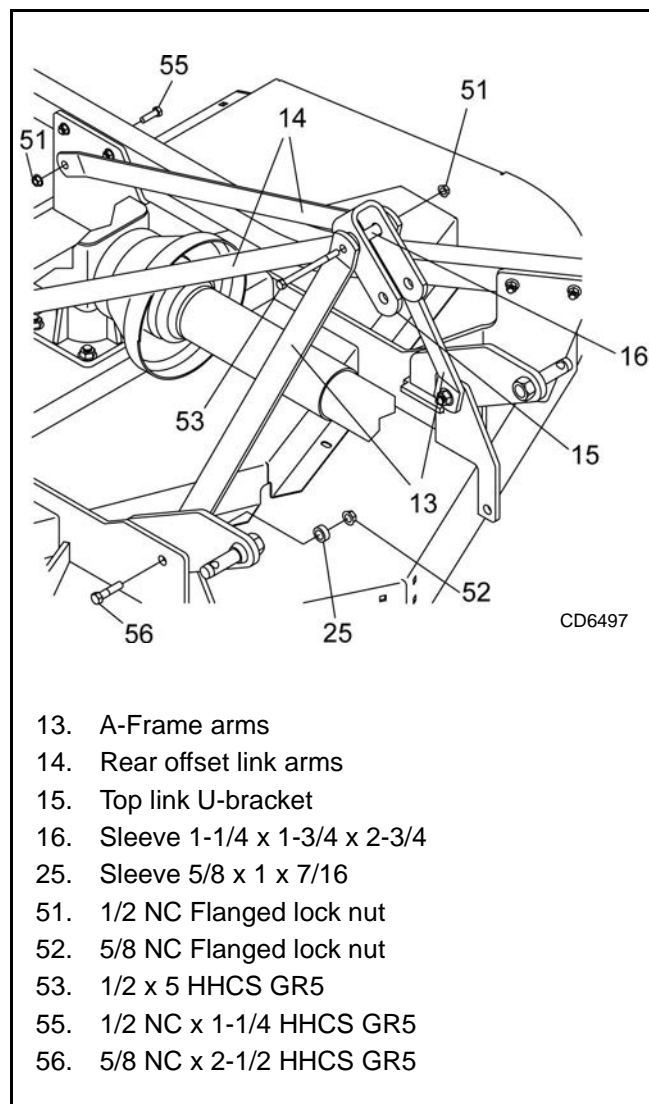

Figure 23. A-Frame Arms Installed

Install Rear Offset Link Arms

1. Loosen nut (51) and bolt (55) at rear frame lug and attach rear offset link arm (14) as shown in Figure 24. (Do not use wheel tube bolt.)
2. Repeat for opposite side.
3. Do not tighten at this time.

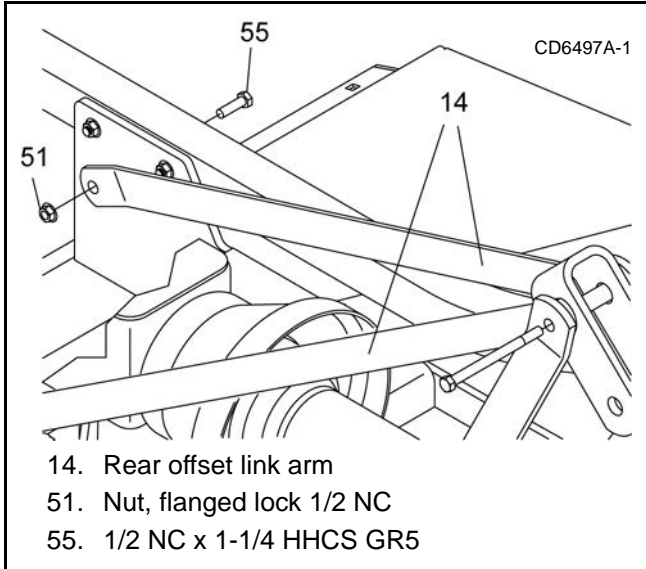

Figure 24. Right Rear Offset Link Installed

Install Top Link

1. Insert cap screw (53) through A-frame arms (13), U-bracket (15), sleeve (16) and rear offset link arms (14) and tighten securely with nut (51).
2. Tighten hardware on rear frame lug and offset link.

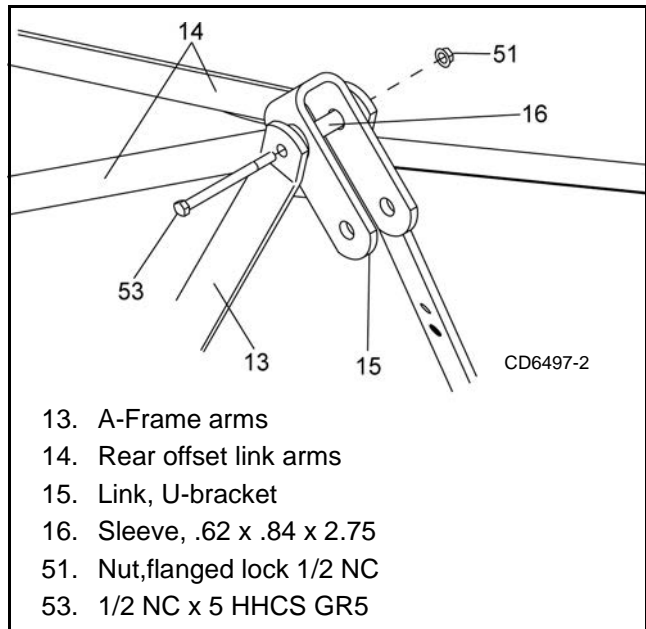

Figure 25. Top Link Assembled

Install Driveshaft

1. Slide QD yoke of driveshaft assembly onto gearbox shaft. Make sure QD yoke pin is seated securely in groove of gearbox shaft.
2. Attach shield anti-rotation chain to drive shield.

Fill Gearbox

1. Make sure vent plug hole is clear. Fill gearbox half-full with high quality gear oil that has a viscosity index of 80W or 90W and an API service rating of GL-4 or GL-5.
2. Fill gearbox until oil runs out the side plug on gearbox.
3. Pour in one pint of gear lube, wait five minutes and add additional gear lube until it just comes out of side hole.
4. Allow an additional five minutes for the lube to flow through bearings, then check to make sure oil level is at bottom of side hole. Replace side plug. Install vent plug.

NOTICE

- Gearbox is not filled at the factory. Prior to delivery, make sure each gearbox is filled half-full with 80W or 90W API GL-4 or GL-5 gear lube.

Install Chain Shielding (Optional)

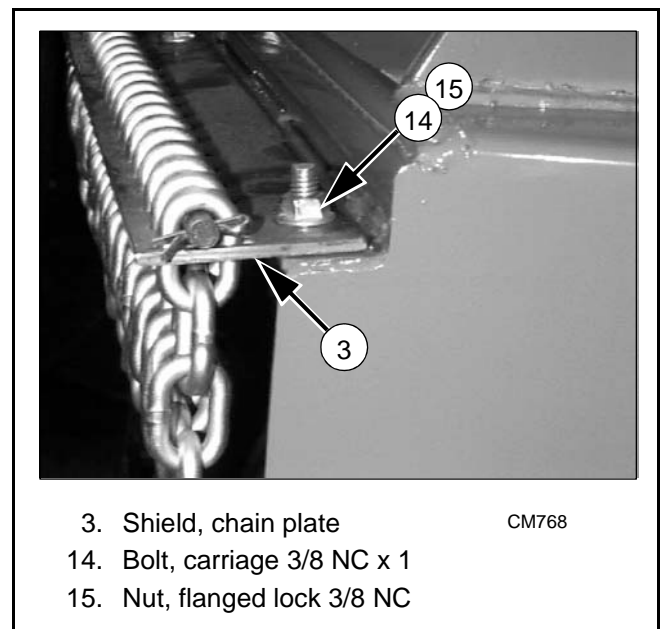

Figure 26. Chain Shielding Installed (GM3060 & GM3072 Only)

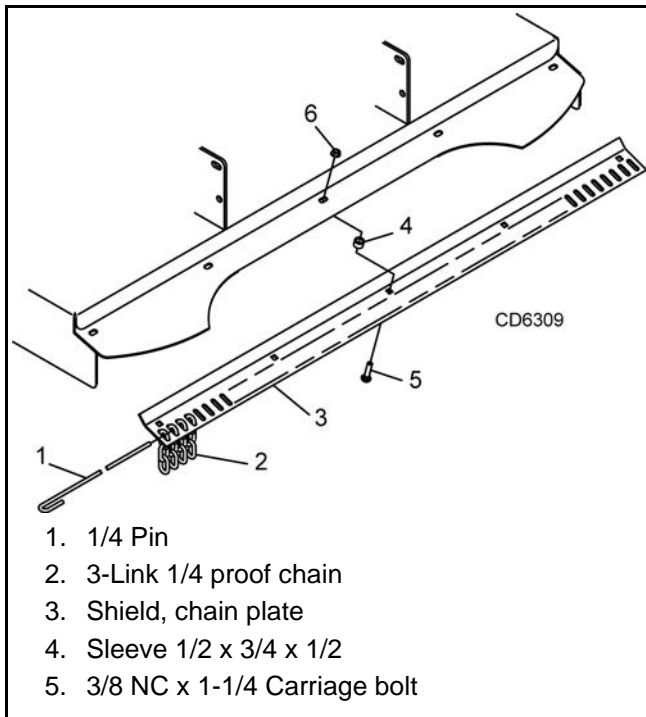

Figure 27. Chain Shield Installed (GM3054 Only)

⚠ DANGER

■ Full chain shielding must be installed when operating in populated areas or other areas where thrown objects could injure people or damage property.

- If this machine is not equipped with full chain shielding, operation must be stopped when anyone comes within 300 feet (92 m).
- This shielding is designed to reduce the risk of thrown objects. The mower deck and protective devices cannot prevent all objects from escaping the blade enclosure in every mowing condition. It is possible for objects to ricochet and escape, traveling as much as 300 feet (92 m).

1. Install chain shielding plate (3) to rear mower frame as shown.
2. Secure with carriage bolts (14) and flanged lock nuts (15).
3. Insert carriage bolts from bottom upward as shown.

Install Quick Hitch Kit (Optional) (GM3060 & GM3072 Only)

NOTE: Figure 28 shows GM3060. Other models use the same assembly instructions.

NOTE: This kit allows mower to fit only Cat. 1 standard ASAE quick hitch.

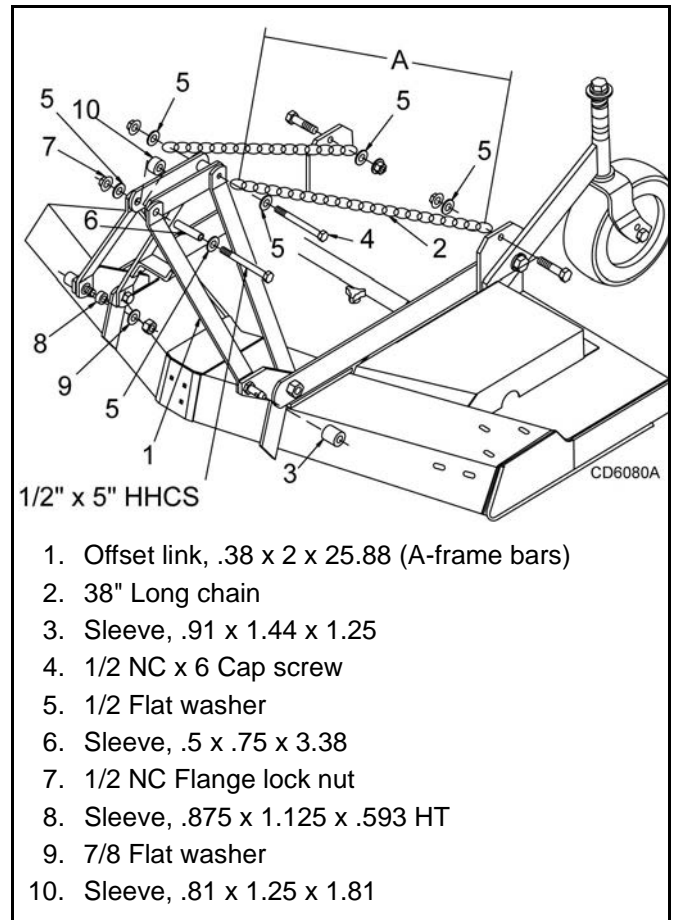

Figure 28. Quick Hitch Kit Installation

1. Attach offset link (1) to mounting pins, using 7/8" sleeve (8) and flat washer (9). Do not tighten hardware.
2. Attach upper end of offset link to pivot link, using flat washer (5), sleeves (6 & 10), flange lock nut (7), and 1/2" x 4-3/4" cap screw.
3. Remove rear offset links and replace with chains (2).
4. Attach chain to top of A-frame as shown, using cap screw (4), flat washer (5), and nut. Attach opposite end of chain (2) to rear mower frame as shown.
5. Cut chain to length (GM3060 - 40", GM3072 45"). Vary length slightly as desired. Twist chain to make finite adjustments in length until unit lifts level.

NOTE: Do not bottom out the drive on front of deck.

6. Install sleeve (3) on mounting pins and retain with klik pin.

Install Front Roller (Optional)

1. Insert four carriage bolts (8) through the front mower frame from inside out.
2. Place roller bracket (2) over bolts; then install flange lock nuts (9) on bolts and tighten.
3. Place front roller (1), sleeve (3), bearings (4), and washers (5) in roller bracket as shown in Figure 29.
4. Insert cap screw (3) through bracket and roller.
5. Secure with flanged lock nut (2). Do not overtighten, roller must spin freely.

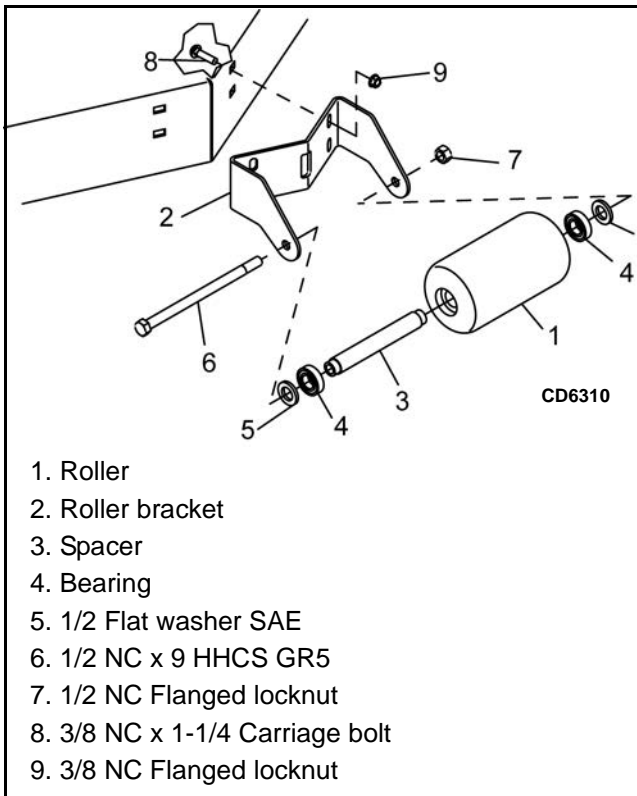

Figure 29. Front Roller Installation

NOTES

DEALER CHECK LISTS

DEALER PRE-DELIVERY CHECK LIST

(DEALER'S RESPONSIBILITY)

Inspect the equipment thoroughly after assembly to ensure it is set up properly before delivering it to the customer.

The following check lists are a reminder of points to inspect. Check off each item as it is found satisfactory or after proper adjustment is made.

- Check that all safety decals are installed and in good condition. Replace if damaged.
- Check that shields and guards are properly installed and in good condition. Replace if damaged.
- Check all bolts to be sure they are properly torqued.
- Check that all cotter pins and safety pins are properly installed. Replace if damaged.
- Check and grease all lubrication points as identified in "lubrication information" on page 14.
- Gearboxes are not filled at the factory. Prior to delivery, fill as specified in the "Service, lubrication information" on page 14 and check to see that there are no leaking seals.
- Check that blades have been properly installed.

DEALER DELIVERY CHECK LIST

(DEALER'S RESPONSIBILITY)

- Show customer how to make adjustments and select proper PTO speed.
- Instruct customer how to lubricate and explain importance of lubrication.
- Point out the safety decals. Explain their meaning and the need to keep them in place and in good condition. Emphasize the increased safety hazards when instructions are not followed.
- Present Operator's Manual and request that customer and all operators read it before operating equipment. Point out the manual safety rules, explain their meanings and emphasize the increased safety hazards that exist when safety rules are not followed.
- Show customer how to make sure driveline is properly installed and that spring-activated locking pin or collar slides freely and is seated in groove on tractor PTO shaft.
- Show customer the safe, proper procedures to be used when mounting, dismounting, and storing equipment.
- Explain to customer the potential crushing hazards of going underneath raised equipment. Instruct that before going underneath to disconnect the driveline, securely block up all corners with jackstands and to follow all instructions in the "Service, blocking methods" section of the Operator's Manual. Explain that blocking up prevents equipment dropping from hydraulic leak down, hydraulic system failures, or mechanical component failures.
- For mounted units, add wheel weights, ballast in front tires, and/or front tractor weight to enhance front end stability. A minimum 25% of tractor and equipment gross weight must be on front tractor wheels. When adding weight to attain 25% of tractor and equipment weight on front tractor wheels, you must not exceed the ROPS weight certification. Weigh the tractor and equipment. Do not estimate!
- Make customer aware of optional equipment available so that customer can make proper choices as required.
- Point out all guards and shields. Explain their importance and the safety hazards that exist when not kept in place and in good condition.

NOTES

Grooming Mowers: GM3054 GM3060 GM3072

MAIN FRAME ASSEMBLY	34 & 35
GEARBOX ASSEMBLY	36
DRIVELINE ASSEMBLY	
GM3054	37
GM3060 & GM3072	38
BLADE & SPINDLE ASSEMBLY	39
BELT GUIDE	39
REAR CHAIN SHIELDING ASSEMBLY (OPTIONAL)	40
FRONT ROLLER ASSEMBLY (OPTIONAL)	41
QUICK HITCH KIT (OPTIONAL)	41

GM3054, GM3060 & GM3072 MAIN FRAME ASSEMBLY

36 - COMPLETE DECAL SET

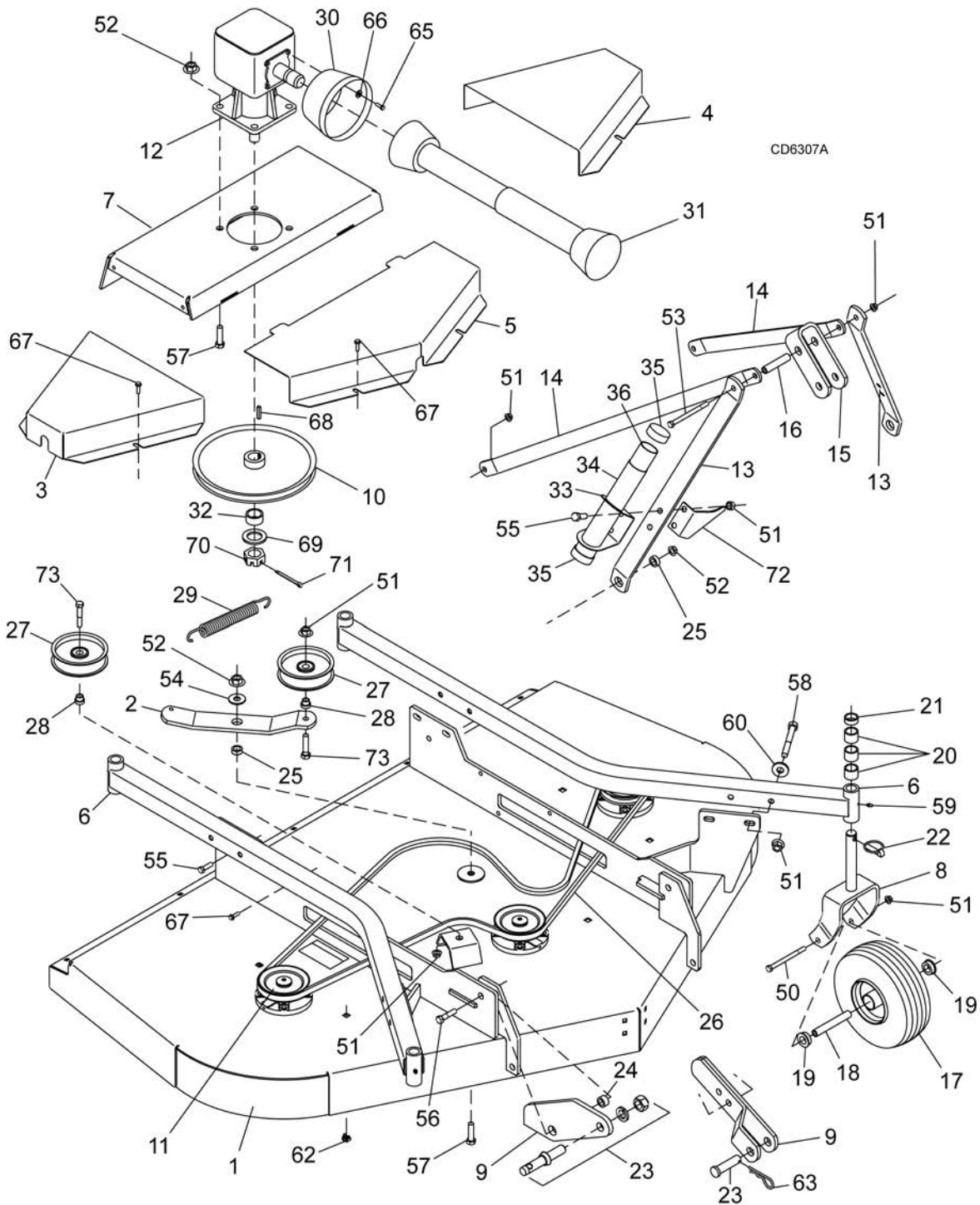

REF	GM3054 PART	GM3060 PART	GM3072 PART	QTY	DESCRIPTION
1	----	----	----	1	Main frame (not sold separately)
2	5WP1008044	5WP1008044	5WP1008044	1	Idler arm
3	5WP1008022	5WP1008069	5WP1008166	1	Right shield
4	5WP1008023	5WP1008069	5WP1008166	1	Left shield
5	5WP1008024	5WP1008167	5WP1008167	1	Center shield

34 Parts

5WPMAN0705 (Rev. 5/9/2008)

GM3054, GM3060 & GM3072 MAIN FRAME ASSEMBLY

REF	GM3054 PART	GM3060 PART	GM3072 PART	QTY	DESCRIPTION
6	5WP1008025	5WP1008085	5WP1008125	2	Caster tube
7	5WP1008028	5WP1008169	5WP1008169	1	Gearbox stand
8	5WP1008030	5WP1008030	5WP1008030	4	Caster yoke (pneumatic tire)
8	5WP1008032	5WP1008032	5WP1008032	4	Caster yoke (solid tire)
9	5WP1008045	5WP18824	5WP18824	2	Hitch
10	5WP1008056	5WP1008056	5WP1008056	1	Gearbox sheave
11	-----	-----	-----	3	Spindle (see page 39)
12	5WP1006649	5WP1006648	5WP1006648	1	Gearbox (see page 36)
13	5WP19579	5WP19579	5WP19579	2	A-frame arm
14	5WP19056	5WP55331	5WP19578	2	Rear offset link arm
15	5WP19605	5WP19605	5WP19605	1	Top link U-bracket
16	5WP64814	5WP64814	5WP64814	1	Sleeve 1-1/4 x 1-3/4 x 2-3/4
17	5WP1008097	5WP1008097	5WP1008097	4	Wheel, 10" pneumatic (includes items 19) -or-
17	5WP1008096	5WP1008096	5WP1008096	4	Wheel, 10" solid (includes items 19)
18	5WP19749	5WP19749	5WP19749	4	Sleeve 1/2 x 3/4 x 4-1/16 (pneumatic tire) -or-
18	5WP29368	5WP29368	5WP29368	4	Sleeve 1/2 x 3/4 x 3-3/8 (solid tire)
19	5WP24993	5WP24993	5WP24993	8	Ball bearing (pneumatic tire) -or-
19	5WP65578	5WP65578	5WP65578	8	Flanged bushing (solid tire)
20	5WP65130	5WP65130	5WP65130	12	1" Height spacer
21	5WP65129	5WP65129	5WP65129	4	1/2" Height spacer
22	5WP27542	5WP27542	5WP27542	4	7/16 Klik pin
23	5WP20409	-----	-----	2	Clevis pin 7/8 x 3 -or-
23	-----	5WP33661	5WP33661	2	Pin, Cat. 1 w/lockwasher & nut
24	-----	5WP1791	5WP1791	2	Sleeve 5/8 x 1 x 9/16
25	5WP484	5WP484	5WP484	3	Sleeve 5/8 x 1 x 7/16
26	5WP20644	5WP20644	5WP18879	1	Belt
27	5WP67283	5WP67283	5WP67283	2	5" Idler
28	5WP67284	5WP67284	5WP67284	1	Shoulder sleeve
29	5WP67131	5WP67131	5WP67131	1	Spring
30	5WP1002048	5WP1002048	5WP1002048	1	Shield
31	5WP1020903	5WP1009508	5WP1009508	1	Driveline
32	-----	5WP1008113	5WP1008113	1	Sleeve 1-1/4 x 1-3/4 x 3/4
33	5WP1008020	5WP1008020	5WP1008020	1	Manual tube holder
34	5WP1004656	5WP1004656	5WP1004656	1	Manual tube - PVC
35	5WP1004657	5WP1004657	5WP1004657	2	Caplug
36	5WP1008196	5WP1008196	5WP1008196	1	Complete decal set

REF	PART REF	DESCRIPTION	REF	PART REF	DESCRIPTION
50	----- *	1/2 NC x 5-1/2 HHCS GR5 (pneumatic tire) -or-	62	5WP100801	3/8 NC Square nut w/retainer
50	----- *	1/2 NC x 5 HHCS GR5 (solid tire)		1	
51	5WP11900	1/2 NC Flanged locknut	63	----- *	3/16 Safety pin
52	5WP19025	5/8 NC Flanged locknut	65	5WP39254	M8 x 1.25 x 16 mm Hex head screw
53	----- *	1/2 NC x 5 HHCS GR5	66	----- *	5/16 Standard flat washer
54	----- *	5/8 Standard flat washer	67	5WP62153	3/8 NC x 1 Hex flange serrated
55	----- *	1/2 NC x 1-1/4 HHCS GR5	68	----- *	1/4 x 1/4 x 1 Key
56	----- *	5/8 NC x 2-1/2 HHCS GR5	69	5WP20893	25 x 44 x 4 mm Flat washer
57	5WP19024	5/8 NC x 1-3/4 Hex head flanged cap screw GR5	70	5WP51946	M24 x 2 Hex castle nut
58	----- *	1/2 NC x 3 HHCS GR5	71	----- *	3/16 x 2 Cotter pin
59	----- *	1/4 - 28 Grease fitting	72	5WP52893	PTO Hanger bracket
60	----- *	1/2 Standard flat washer	73	----- *	1/2 NC x 1-3/4 HHCS GR5
					* Standard Hardware, Obtain Locally

GM3054, GM3060 & GM3072 GEARBOX ASSEMBLY

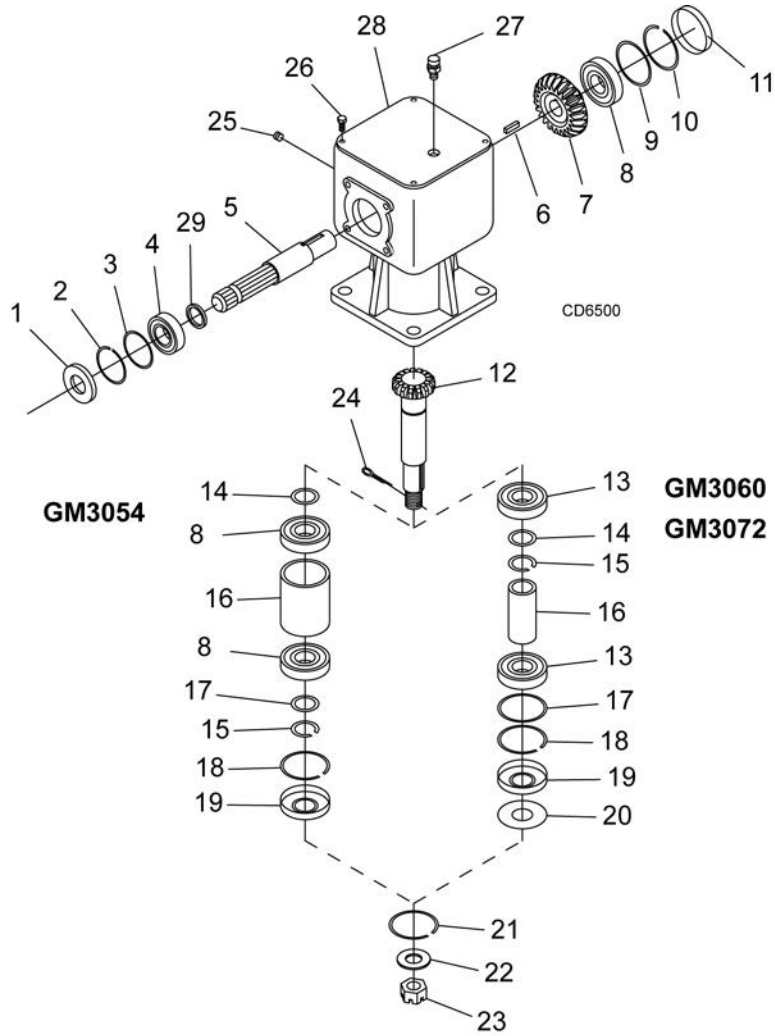

REFGM3054		REFGM3060 / GM3072		DESCRIPTION	REFGM3054		REFGM3060 / GM3072		DESC		
REF	PART	QTY	PART		QTY	REF	PART	QTY		PART	QTY
A	5WP1006649	1	5WP1006648	1	Complete gearbox	18	5WP57466	1	5WP39251	1	Snap ring
1	5WP39275	1	5WP39275	1	Seal	19	5WP57463	1	5WP20900	1	Seal
2	5WP1007861	1	5WP1007861	1	Snap ring	20	-----	1	5WP20888	1	Washer, x .04
3	5WP1007865	1	5WP1007865	1	Shim kit	21	5WP1007860	1	5WP20897	1	Snap ring
4	5WP51850	1	5WP51850	1	Ball bearing	22	5WP20893	1	5WP20893	1	Washer : mm
5	NSS	1	NSS	1	Input shaft	23	5WP51946	1	5WP51946	1	Castle nut
6	5WP20894	1	5WP20894	1	Key 8 x 10 x 30 mm	24	-----	* 1	-----	* 1	3/16 x 2
7	NSS	1	NSS	1	Input gear	25	NSS	1	NSS	1	3/8 Solid
8	5WP20890	4	5WP20890	1	Ball bearing	26	NSS	4	NSS	4	M10 x 22 screw
9	5WP1007864	1	5WP1007864	1	Shim kit	27	5WP39325	1	5WP39325	1	Vent plug
10	5WP57466	1	5WP57466	1	Snap ring	28	5WP1007873	1	5WP1007873	1	Cover
11	5WP57374	1	5WP57374	1	Oil cap	29	5WP1007857	1	-----	1	Spacer
12	NSS	1	NSS	1	Output shaft & gear						
13	-----	1	5WP20891	2	Ball bearing						
14	5WP1007866	1	5WP1007863	1	Shim kit						
15	5WP1007859	1	5WP20895	1	Snap ring						
16	5WP1007858	1	5WP20886	1	Spacer						
17	5WP1007862	1	5WP1007862	1	Shim kit						

* Standard hardware, obtain NSS Not sold separately

36 Parts

5WPMAN0705 (Rev. 5/9/2008)

GM3054 DRIVELINE ASSEMBLY

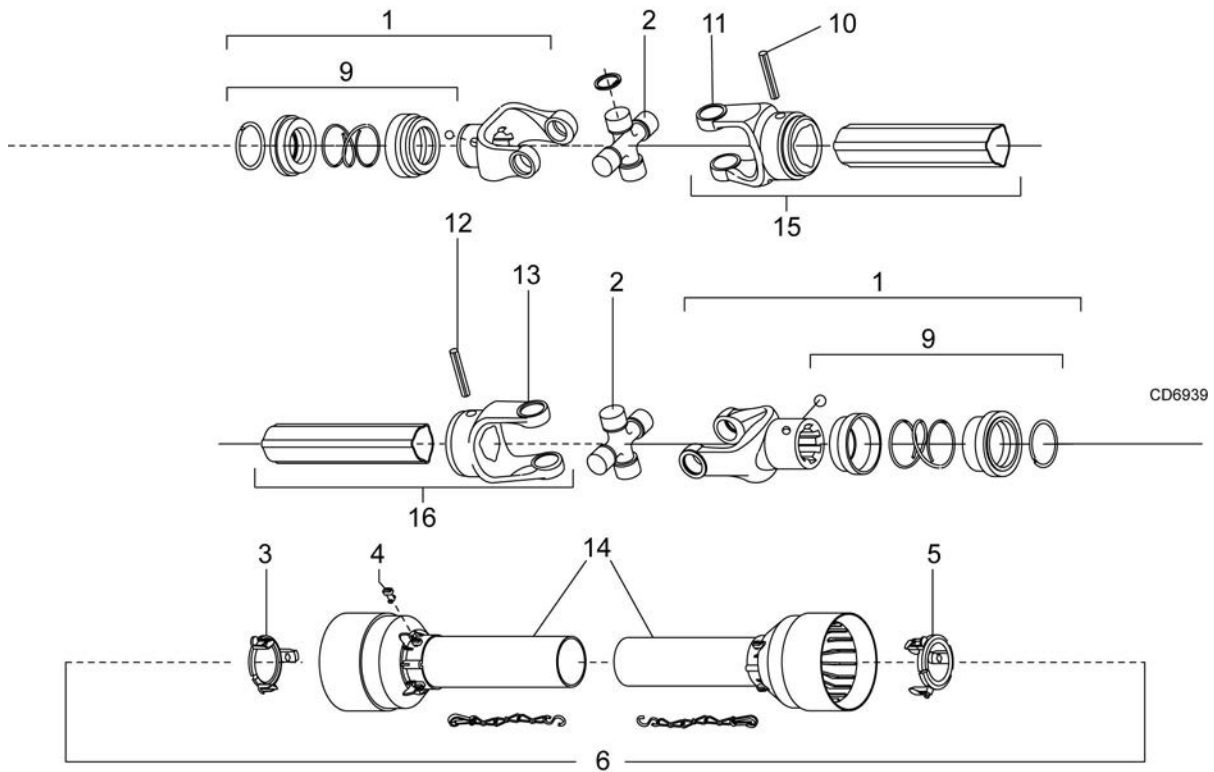

REF	PART	QTY	DESCRIPTION	REF	PART	QTY	DESCRIPTION
A	5WP1020903	1	Complete driveline assembly	10	5WP1001302	1	Flexible pin
1	5WP1001300	2	Complete collar yoke C12 1-3/8 - 6	11	5WP1001301	1	Outer yoke tube
2	5WP38478	2	Cross and bearing kit	12	5WP1001305	1	Flexible pin
3	5WP1019442	1	Outer cone fix ring	13	5WP1001306	1	Inner tube yoke
4	5WP30922	6	Protection fixing screw	14	5WP1021554	1	Complete shield
5	5WP1019444	1	Inner cone fix ring	15	5WP30926	1	Outer yoke & tube (must be cut to length)
6	5WP30917	2	Chain shielding tether	16	5WP30932	1	Inner yoke & tube (must be cut to length)
9	5WP1001340	1	Lock collar repair kit				

GM3060 & GM3072 DRIVELINE ASSEMBLY

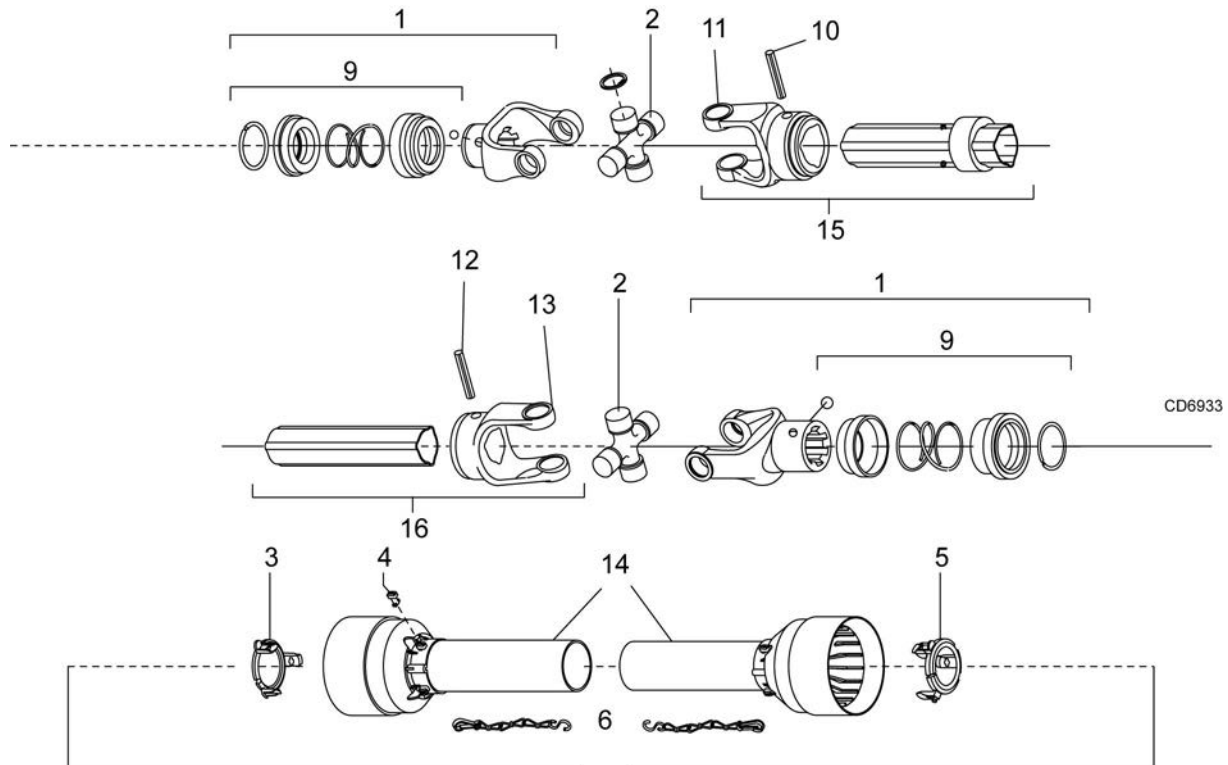

REF	PART	QTY	DESCRIPTION
A	5WP1009508	1	Complete driveline assembly
1	5WP1001300	2	Complete collar yoke C12 1-3/8 - 6
2	5WP38478	2	Cross and bearing kit
3	5WP1019442	1	Outer cone fix ring
4	5WP30922	6	Protective fixing screw
5	5WP1019444	1	Inner cone fix ring
6	5WP30917	2	Chain shield tether
9	5WP1001340	1	Lock collar repair kit

REF	PART	QTY	DESCRIPTION
10	5WP1001302	1	Flexible pin
11	5WP1001301	1	Outer yoke tube
12	5WP1001305	1	Flexible pin
13	5WP1001306	1	Inner tube yoke
14	5WP1021323	1	Complete shield
15	5WP30926	1	Outer yoke & tube (must be cut to length)
16	5WP30932	1	Inner yoke & tube (must be cut to length)

GM3054, GM3060 & GM3072 BLADE & SPINDLE ASSEMBLY

REF	PART	QTY	DESCRIPTION
A	5WP1009080	1	Complete spindle assembly (includes 1, 2, 4, 5 through 12, 14 & 15)
1	-----*	1	3/8 NF x 1 HHCS GR5
2	5WP70005	1	Cup washer
3	5WP1008059	1	Sheave (GM3054) -or-
3	5WP1008057	1	Sheave (GM3060) -or-
3	5WP1008040	1	Sheave (GM3072)
4	5WP1008055	1	Spacer
5	5WP72933	2	Spindle bearing
6	5WP14350	4	3/8 NC Flange locknut
7	-----*	1	1/4 Tapered grease fitting
8	5WP1008053	1	Spindle housing
9	-----*	4	3/8 NC x 1-1/2 HHCS GR5
10	5WP1008052	1	Spacer
11	-----*	1	Square key, .25 x .25 x .69
12	5WP1008042	1	Shaft assembly
13	5WP78127KT	1	Blade kit, high suction 18.7" (includes 3 blades)(GM3054) -or-
13	5WP1001513KT	1	Blade kit, high suction 21" (includes 3 blades)(GM3060) -or-
13	5WP1008199KT	1	Blade kit, high suction 25" (includes 3 blades)(GM3072)
14	5WP10635	2	Cup washer
15	5WP1008095	1	5/8 NF x 2 HHCS GR5

* Standard Hardware - Obtain Locally

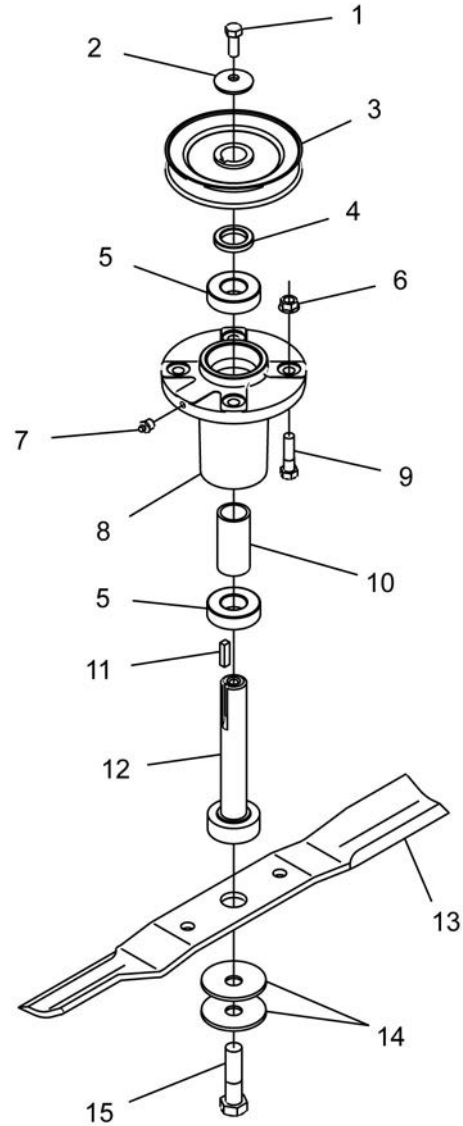

GM3054R, GM3060R, GM3072R BELT GUIDE

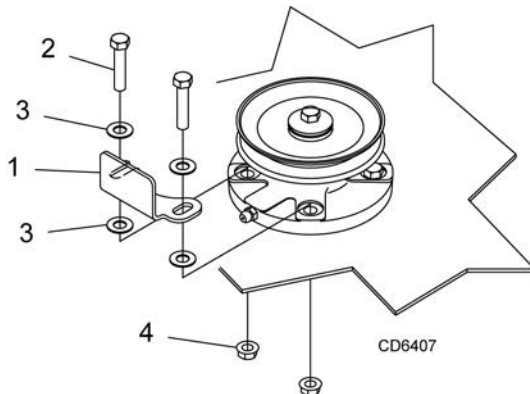

REF	PART	QTY	DESCRIPTION
A	5WP1008181	1	Belt guide kit
1	NSS	1	Belt guide
2	-----*	2	3/8 NC x 2 Cap screw GR5
3	-----*	4	3/8 SAE Flat washer
4	5WP14350	2	3/8 NC Flange lock nut (not included)

* Standard hardware, obtain locally

NSS Not sold separately

GM3060 & GM3072 REAR CHAIN SHIELDING ASSEMBLY (OPTIONAL)

REF	PART	QTY	DESCRIPTION
A	5WD55348		Chain shield assembly (GM3060)
B	5WD53566		Chain shield assembly (GM3072)
1	5WP1007854	1	Pin, 40 to 42 chains (for GM3060 only) -or-
1	5WP1007856	1	Pin, 52 to 54 chains (for GM3072 only)
2	5WP4763		Chain, 3-link, 1/4 proof (use 54 for GM3060; 60 for GM3072)

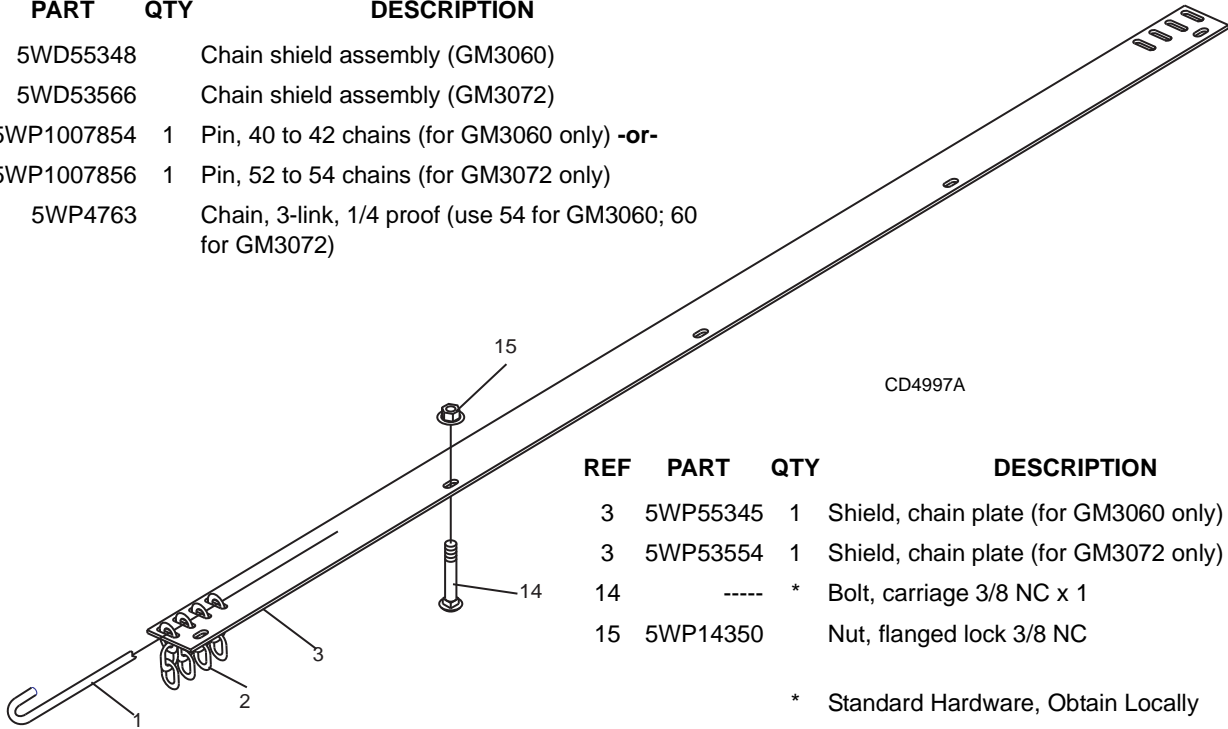

REF	PART	QTY	DESCRIPTION
3	5WP55345	1	Shield, chain plate (for GM3060 only) -or-
3	5WP53554	1	Shield, chain plate (for GM3072 only)
14	-----	*	Bolt, carriage 3/8 NC x 1
15	5WP14350		Nut, flanged lock 3/8 NC

* Standard Hardware, Obtain Locally

GM3054 REAR CHAIN SHIELD ASSEMBLY (OPTIONAL)

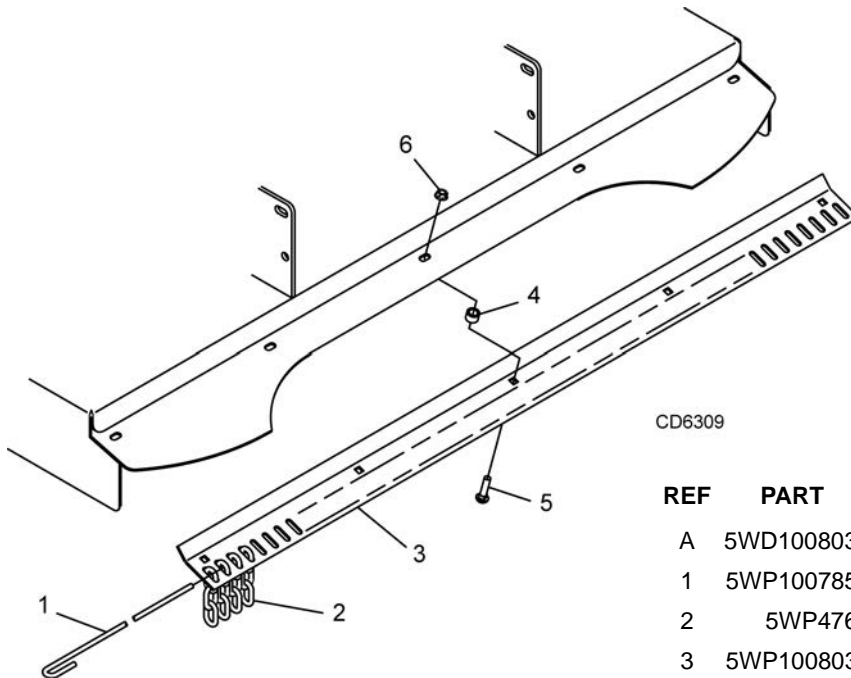

CD6309

REF	PART	QTY	DESCRIPTION
A	5WD1008038		Chain shield assembly
1	5WP1007854	1	1/4 Pin
2	5WP4763	49	3-Link 1/4 proof chain
3	5WP1008037	1	Chain shield plate
4	5WP22086	5	Sleeve 1/2 x 3/4 x 1/2
5	-----*	5	3/8 NC x 1-1/4 Carriage bolt
6	5WP14350	5	3/8 NC Flanged locknut

* Standard Hardware, Obtain Locally

40 Parts

5WPMAN0705 (Rev. 5/9/2008)

GM3054, GM3060 & GM3072 FRONT ROLLER ASSEMBLY (OPTIONAL)

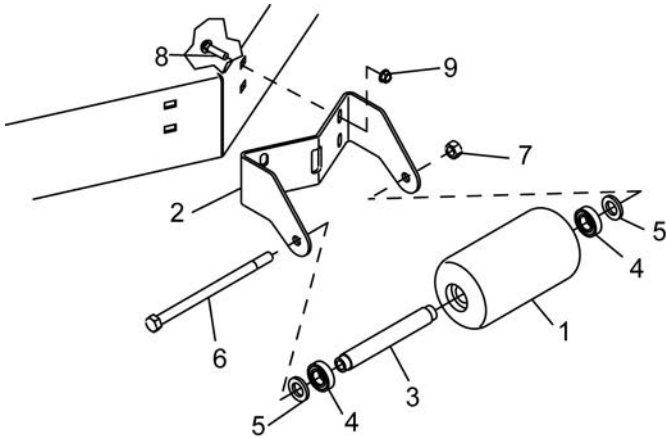

REF	PART	QTY	DESCRIPTION
A	5WD1008035K T	1	Front roller kit, complete
1	5WP1006418	1	Roller
2	5WP1008034	1	Roller bracket
3	5WP1006420	1	Spacer
4	5WP35193	2	Bearing
5	-----*	2	1/2 Flat washer SAE
6	5WP38107	1	1/2 NC x 9 HHCS GR5
7	5WP11900	1	1/2 NC Flanged locknut
8	-----*	4	3/8 NC x 1-1/4 Carriage bolt
9	5WP14350	4	3/8 NC Flanged locknut

* Standard Hardware, Obtain Locally

GM3060 & GM3072 QUICK HITCH KIT (OPTIONAL)

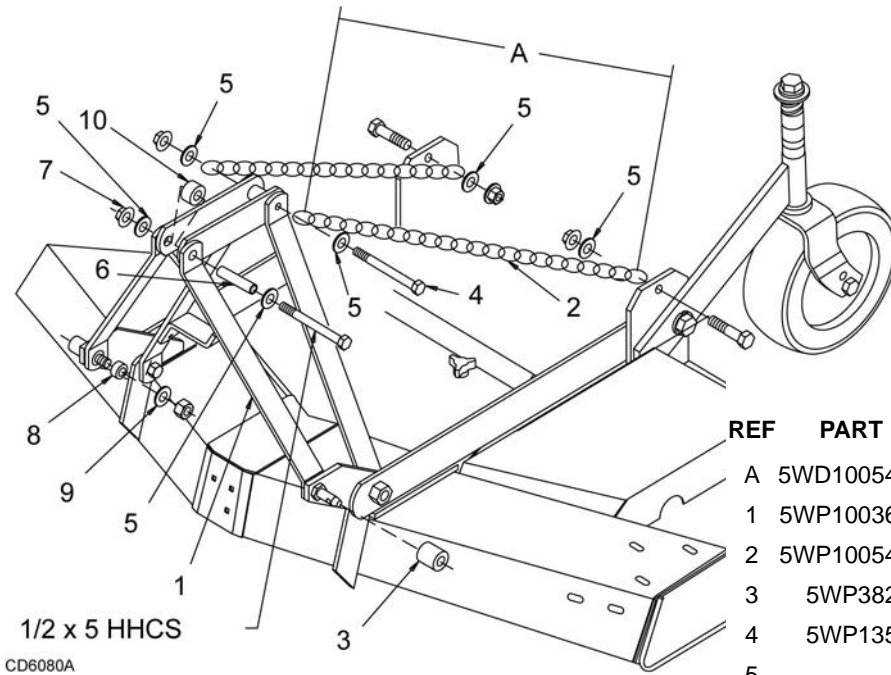

1/2 x 5 HHCS
CD6080A

REF	PART	QTY	DESCRIPTION
A	5WD1005400	1	Complete quick hitch kit
1	5WP1003692	2	Link, offset .38 x 2.0 x 15
2	5WP1005401	2	Chain 3/8 proof coil 38 link
3	5WP38214	2	Sleeve, .91 x 1.44 x 1.25
4	5WP13563	1	Screw, HHCS 1/2 NC x 6 GR5
5	-----*	6	Washer, flat 1/2 ZP
6	5WP29368	1	Sleeve, .50 x .75 x 3.38
7	5WP11900	1	Nut, flange lock 1/2 NC
8	5WP29281	2	Sleeve, 7/8 x 1-1/8 x 19/32 HT
9	-----*	2	Washer, flat 7/8
10	5WP1003614	1	Sleeve, .81 x 1.25 x 1.81

* Standard Hardware, Obtain Locally

BOLT TORQUE CHART

Always tighten hardware to these values unless a different torque value or tightening procedure is listed for a specific application.

Fasteners must always be replaced with the same grade as specified in the manual parts list.

Always use the proper tool for tightening hardware: SAE for SAE hardware and Metric for metric hardware.

Make sure fastener threads are clean and you start thread engagement properly.

All torque values are given to specifications used on hardware defined by SAE J1701 MAR 99 & J1701M JUL 96.

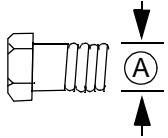

SAE SERIES TORQUE CHART



SAE Grade 2
(No Dashes)

SAE Bolt Head Identification



SAE Grade 5
(3 Radial Dashes)



SAE Grade 8
(6 Radial Dashes)

Ⓐ Diameter (Inches)	Wrench Size	MARKING ON HEAD					
		SAE 2		SAE 5		SAE 8	
		lbs-ft	N-m	lbs-ft	N-m	lbs-ft	N-m
1/4"	7/16"	6	8	10	13	14	18
5/16"	1/2"	12	17	19	26	27	37
3/8"	9/16"	23	31	35	47	49	67
7/16"	5/8"	36	48	55	75	78	106
1/2"	3/4"	55	75	85	115	120	163
9/16"	13/16"	78	106	121	164	171	232
5/8"	15/16"	110	149	170	230	240	325
3/4"	1-1/8"	192	261	297	403	420	569
7/8"	1-5/16"	306	416	474	642	669	907
1"	1-1/2"	467	634	722	979	1020	1383

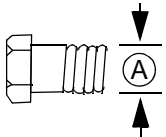

METRIC SERIES TORQUE CHART



Metric
Grade 8.8

Metric Bolt Head Identification



Metric
Grade 10.9

Ⓐ Diameter & Thread Pitch (Millimeters)	Wrench Size	Coarse Thread				Fine Thread				Ⓐ Diameter & Thread Pitch (Millimeters)
		Marking on Head				Marking on Head				
		Metric 8.8		Metric 10.9		Metric 8.8		Metric 10.9		
		N-m	lbs-ft	N-m	lbs-ft	N-m	lbs-ft	N-m	lbs-ft	
6 x 1.0	10 mm	8	6	11	8	8	6	11	8	6 x 1.0
8 x 1.25	13 mm	20	15	27	20	21	16	29	22	8 x 1.0
10 x 1.5	16 mm	39	29	54	40	41	30	57	42	10 x 1.25
12 x 1.75	18 mm	68	50	94	70	75	55	103	76	12 x 1.25
14 x 2.0	21 mm	109	80	151	111	118	87	163	120	14 x 1.5
16 x 2.0	24 mm	169	125	234	173	181	133	250	184	16 x 1.5
18 x 2.5	27 mm	234	172	323	239	263	194	363	268	18 x 1.5
20 x 2.5	30 mm	330	244	457	337	367	270	507	374	20 x 1.5
22 x 2.5	34 mm	451	332	623	460	495	365	684	505	22 x 1.5
24 x 3.0	36 mm	571	421	790	583	623	459	861	635	24 x 2.0
30 x 3.0	46 mm	1175	867	1626	1199	1258	928	1740	1283	30 x 2.0

Typical Washer Installations

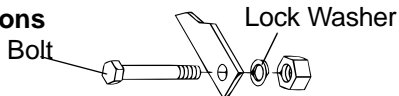

Flat Washer

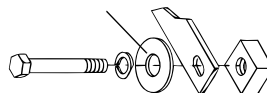

8/9/00

BOLT SIZE CHART

NOTE: Chart shows bolt thread sizes and corresponding head (wrench) sizes for standard SAE and metric bolts.

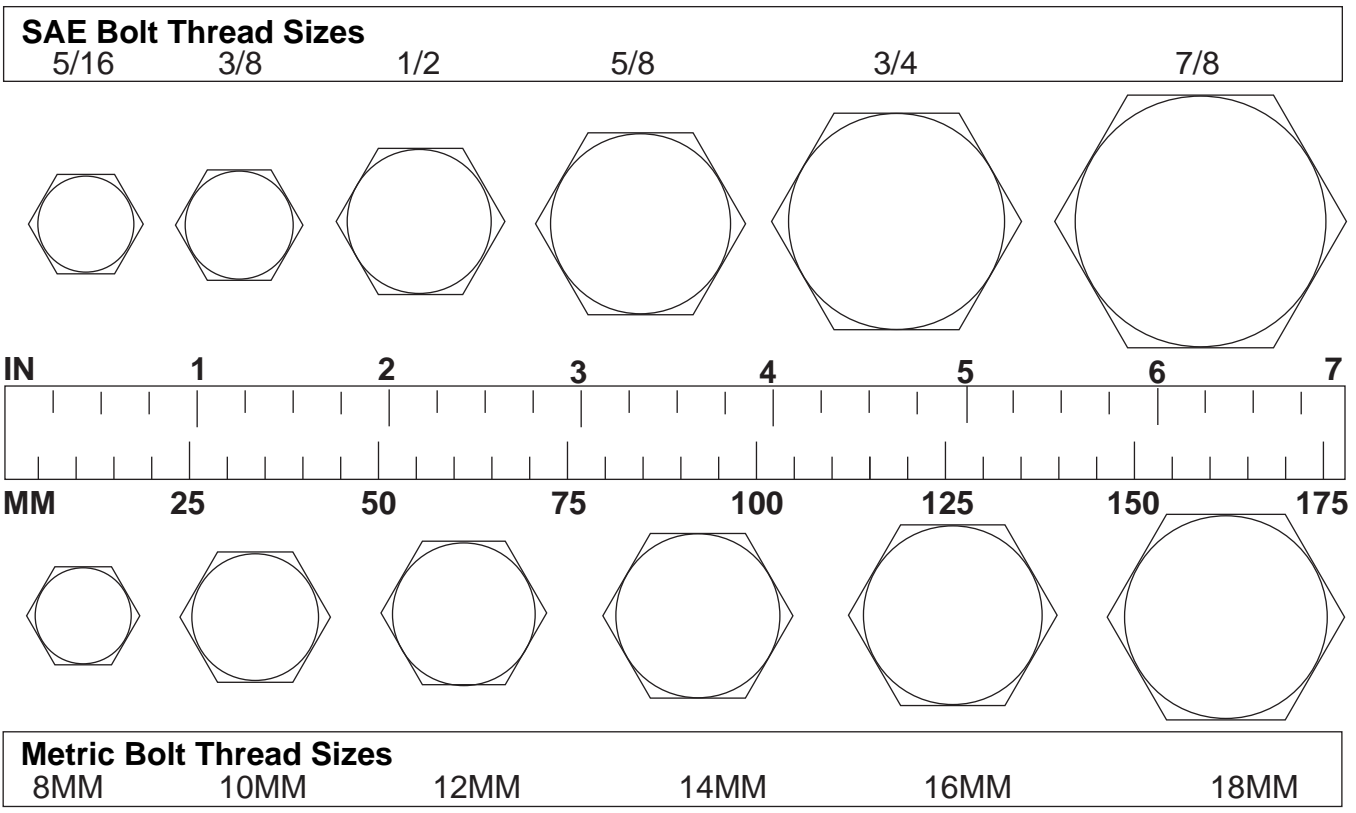

ABBREVIATIONS

<p>AG Agriculture</p> <p>ASABE American Society of Agricultural & Biological Engineers (formerly ASAE)</p> <p>ASAE American Society of Agricultural Engineers</p> <p>ATF Automatic Transmission Fluid</p> <p>BSPP British Standard Pipe Parallel</p> <p>BSPTM British Standard Pipe Tapered Male</p> <p>CV Constant Velocity</p> <p>CCW Counter-Clockwise</p> <p>CW Clockwise</p> <p>F Female</p> <p>FT Full Thread</p> <p>GA Gauge</p> <p>GR (5, etc.) Grade (5, etc.)</p> <p>HHCS Hex Head Cap Screw</p> <p>HT Heat-Treated</p> <p>JIC Joint Industry Council 37° Degree Flare</p> <p>LH Left Hand</p> <p>LT Left</p> <p>m Meter</p> <p>mm Millimeter</p> <p>M Male</p>	<p>MPa Mega Pascal</p> <p>N Newton</p> <p>NC National Coarse</p> <p>NF National Fine</p> <p>NPSM National Pipe Straight Mechanical</p> <p>NPT National Pipe Tapered</p> <p>NPT SWF National Pipe Tapered Swivel Female</p> <p>ORBM O-Ring Boss - Male</p> <p>P Pitch</p> <p>PBY Power-Beyond</p> <p>psi Pounds per Square Inch</p> <p>PTO Power Take Off</p> <p>QD Quick Disconnect</p> <p>RH Right Hand</p> <p>ROPS Roll-Over Protective Structure</p> <p>RPM Revolutions Per Minute</p> <p>RT Right</p> <p>SAE Society of Automotive Engineers</p> <p>UNC Unified Coarse</p> <p>UNF Unified Fine</p> <p>UNS Unified Special</p>
---	---

INDEX

ADJUSTMENTS

- Cutting Height 11
- Tractor Top Link 11

ASSEMBLY

- Dealer Set-Up Instructions 27
- Initial Gearbox Oil Fill 28
- Optional Equipment
 - Chain Shielding 28
 - Front Roller 30
 - Quick Hitch Kit 29

DEALER CHECK LISTS

- Delivery (Dealer's Responsibility) 31
- Pre-Delivery (Dealer's Responsibility) 31

DEALER SERVICE

- Blade Spindle
 - Assembly 21
 - Disassembly 21
 - Removal 20
 - Repair 20
- Blocking Method 20
- Drive Sheave Installation 24
- Gearbox
 - Disassembly 23
 - Horizontal Shaft Seal Replacement 23
 - Installation 24
 - Reassembly 23
 - Removal 23
 - Repair 21
 - Seal Installation 21
 - Seal Replacement 21
 - Vertical Shaft Seal Replacement 22
- Universal Joint
 - Assembly 26
 - Disassembly 25
 - Repair 24

GENERAL

- Abbreviations 43
- Bolt Size Chart 43
- Bolt Torque Chart 42
- General Information 4
- Introduction 2
- Specifications 4

OPERATION

- Attaching Mower to Tractor 10
- Cutting Height Adjustment 11
- Front Caster Wheel Interference Check 12
- Front Roller (Optional) 12

- Mowing Speed 10
- Operating
 - On Uneven Terrain 13
 - Technique 12
 - Tips 12
- Owner Pre-Operation Check List (Owner's Responsibility) 13
- Removing Mower from Tractor 13
- Storage 13
- Tractor Stability 10
- Tractor Top Link Adjustment 11

OWNER SERVICE

- Belt
 - Installation 16
 - Replacement 16
 - Routing 16
 - Service 16
- Blade
 - Installation 17
 - Removal 16
 - Service 16
 - Sharpening 16
- Blocking Method 14
- Chain Shielding 17
- Cleaning 17
- Lubrication
 - Chart 15
 - Driveshaft 15
 - Information 14
 - Points 15

PARTS

- Parts Index 33

SAFETY

- Blocking Method 14
- Check Lists
 - Delivery (Dealer's Responsibility) 31
 - Pre-Delivery (Dealer's Responsibility) 31
 - Pre-Operation (Owner's Responsibility) 13
- Jackstand Placement 14
- Safety & Instructional Decals 8, 9
- Safety Rules 5, 6, 7

TROUBLESHOOTING

- Belt Conditions 19
- Mowing Conditions 18

NOTES

PART NUMBER
5WPMAN0705